

# Connecting USB Ports of Personal Computers by Changing Kinect With Sensors

Ivaylo Vladimirov, Desislava Nikolova, Zornitsa Terneva  
Technical University of Sofia  
8 Kl. Ohridski Blvd  
Sofia 1000  
Bulgaria  
{i\_vladimirov@mail.bg}, {desislava.v.nikolova@gmail.com}, {z.terneva@abv.bg}



**ABSTRACT:** Normally the Microsoft OEM adapter is deployed to connect the USB port in personal computers. However, we have introduced models for changing the Kinect v2 sensor in order to connect the USB. To do so, we took the elements such as Kinect v2, Power supply adapter, F144 DC chassis jack, USB 3.0 cable type A-B, single conductor cable and a soldering iron. Our intention is to use other systems to connect Kinect and PC because the Microsoft has now has discontinued the production of Kinect v2 adapters.

**Keywords:** Kinect v2 Sensor, Modification, Microsoft OEM Adapter, USB 3.0 Cable Type A-B, Power Supply Adapter, F144 DC Chassis Jack

**Received:** 24 March 2020, Revised 13 June 2020, Accepted 28 June 2020

**Copyright:** With Authors

## I. Introduction

The Kinect device is a motion-sensing sensor made by Microsoft as an accessory for the Xbox gaming console, but it also works with PCs. The various cameras and sensors that the Kinect has, enable it to sense movement just as well in the dark as to when it is well lit. It's due to the 3 constantly illuminating infra-red projectors emitting over the observed scene [1] [2].

The first sensor is an RGB camera that is able to capture full HD quality images up to resolutions of 1920 x 1080 p [1].

The second one is an infrared depth camera that unlike the color camera sees information in the 3-Dimensional plane, It has a resolution of  $512 \times 424$  pixels and can sense high fidelity depth information using infrared sensors and recreate a 3-D view of what the Kinect senses [1]. The Kinect uses this information to perform body tracking from the depth data that it captures. It is smart enough to track up to six people with 25 joints on each person [3]. This information can then be used in applications that require human body interactions for example in healthcare applications for physical therapy, or in interactive games [4].

The third and last sensor is a microphone array consisting of four microphones. If a person wants to interact with the device, using his voice the array detects the direction of the sound source and amplifies the sound from one direction while suppress-

ing the noise coming from other directions. Another use of these microphones is to find the location of a person and estimate his/her coordinates [5].

## 2. The Problem

The usage of the Kinect sensor has progressed way beyond conventional methods when it was only used to make applications and games solely for the Xbox console. The introduction of the Kinect to the PC platform by Microsoft in 2011 and the release of the software development kit (SDK), paved the way for developers to start thinking out of the box to create more interesting, innovative and ground-breaking ways to use the sensor [1].

Today, many businesses and education institutions have taken on the challenge of experimenting and implementing Kinect driven systems into their business processes, projects and work, in order to overcome certain barriers and pave the way for new developments, innovations and inventions [6].

The adapter (fig.1) consists of two main components: the USB adapter itself and the power supply. The USB adapter is a 1.0 by 1.6 by 3.4 inch black block. It has a Kinect port on one end and an USB 3.0 type B and power ports on the other. The Kinect plugs into the Kinect port, and the USB port connects via the included USB 3.0 B-to-A cable to the PC or Xbox One S. The separate 1.0 by 2.0 by 3.4 inch power supply plugs into the power connector with its own attached cable, and the included power cable connects that to any power outlet [7].

But in April 2015 Microsoft decided to stop manufacturing Kinects v2 sensors [8] and respectively in October 2017 - their adapters. The Kinect adaptor is already out of stock at almost every major retailer, leaving users still hoping to use a Kinect at the mercy of the second-hand market, where the adapter runs for between \$150 to \$300, making it an incredibly expensive proposition for anyone hoping to pick up a Kinect for their Xbox One or ever make use of one currently collecting dust in a closet [9].

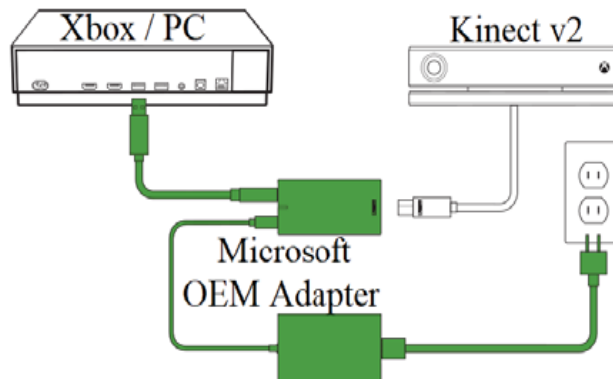

Figure 1. Diagram showing how to connect the adapter

And so, with Microsoft's official confirmation on stopping the production of Kinect Adaptors, it seems that it's time to close the book on the motion gaming era once and for all - at least until someone tries to resurrect the idea [9].

## 3. The Solution

The decision of Microsoft Corporation resulted in us trying to find a way to connect a Kinect device to a PC without an original OEM adapter. After an initial research [10] [11] [12] we decided to modify the Kinect sensor using a USB 3.0 Type A-B cable, where the Type A connector is for the attachment to the PC and the Type B is for the Kinect and a DC power supply adapter 12V/3A with a F138N DC PLUG 2.5x5.5. See figure 2 for a general scheme of the modification.

The power supply was needed to be soldered via a soldering iron to two pins on the printed circuit board – the ground (GND) and the +12V pin. Figure 3 presents the theoretical approach on the left and the practically realized one on the right.

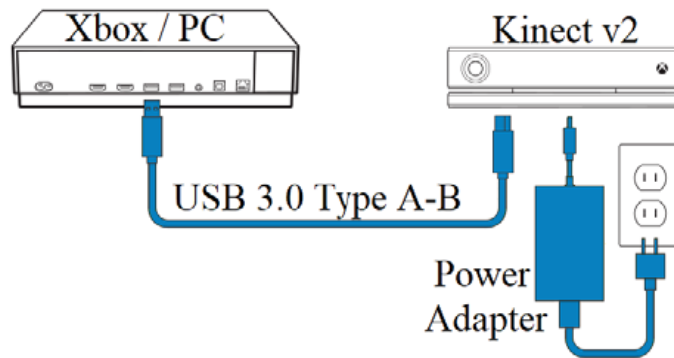

Figure 2. Diagram showing our solution

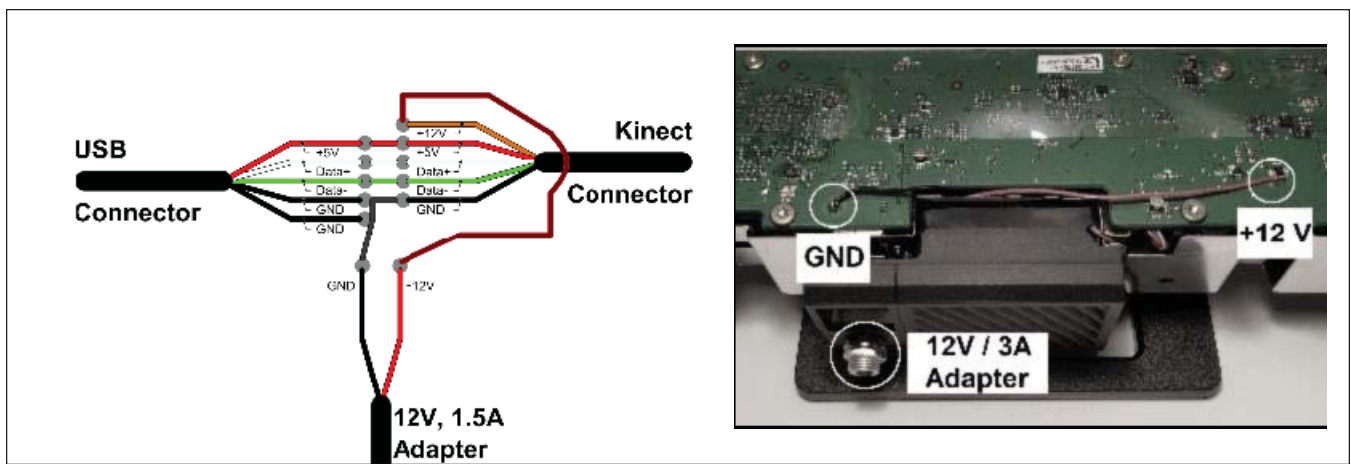

Figure 3. Connection schemes for the power supply

Another adaptation that needs to be made is the addition of an F144 DC chassis jack. This jack gives the power supply the capability to be easily removed or plugged in and also makes the Kinect sensor more mobile in case of a need for a repair or just to be moved. The position of the F144 connector is secure, safe and it doesn't touch the protective screen. Figure 3 shows: on the left – the F144 jack before installation; in the middle – a view of the connector from the inside-out; on the right – the jack after its installation on the Kinect chassis.



Figure 4. The F144 DC Chassis Jack

The result of the whole process is presented on figure 4.

#### 4. Conclusion

The given solution is not only time effective but it also saves money, the prices of the used parts in dollars are: USB 3.0 cable - 9\$, power supply adapter - 10\$, F144 jack - 1\$. When comparing the total price with the price of an OEM adaptor (20\$ to about 100\$), we can see that the reduction of the cost is about 80%. The device is tested and no problems have been found.



Figure 5. The final result of the modification

#### Acknowledgement

The authors would like to thank the professors at the Faculty of Telecommunication, TU – Sofia. In particular Prof. V. Poulkov, K. Tonchev, N. Dandanov and A. Ivanov from the Teleinfrastructure Research Lab at TU-Sofia for letting us compare the modified Kinect sensor and the combination of the Kinect and OEM devices.

#### References

- [1] Kinect for Windows. Available online: <https://microsoft.com/en-us/kinectforwindows/default.aspx>
- [2] Lachat, E., Macher, H., Landes, T., Grussenmeyer, P. (2015). Assessment and Calibration of a RGB-D Camera (Kinect v2 Sensor) Towards a Potential Use for Close-Range 3D Modeling, 2015.
- [3] Lachat, E., Macher, H., Mittet, M.-A., Landes, T., Grussenmeyer, P. (2015). First experiences with Kinect v2 sensor for close range modelling. *INSA Strasbourg*, 25-27, February 2015
- [4] PALIYAWAN Pujana. (2018). Intelligent Middleware for Healthy Motion Gaming, Doctoral Dissertation, September.
- [5] Pei, Ling., Chen, Liang., Guinness, Robert., Liu, Jingbin., Kuusniemi, Heidi., Chen, Yuwei, Chen, Ruizhi, Söderholm, Stefan. (2013). *Sound positioning using a small-scale linear microphone array*, IPIN Conference, 28-31, (October).
- [6] Abolhoseini, S., Sadeqi-Niaraki, A., Abbasi, O. R. (2015). Overview of Microsoft Kinect applications in ubiquitous GIS.
- [7] Greenwald, Will. (2016). Microsoft Kinect Adapter for Windows, <https://www.pcmag.com>, August.
- [8] EMIL PROTALINSKI, Microsoft stops producing Kinect for Windows v2 sensor, will focus on Kinect for Xbox One and Windows apps, <https://venturebeat.com>, April, 2015
- [9] Chaim Gartenberg. (2018). Microsoft has discontinued the Kinect Adapter for newer Xbox One consoles, <https://www.theverge.com>, January.
- [10] How to Hack Xbox One Kinect to Work on Windows 10 PC, available online: <https://youtube.com/watch?v=l0rWWT24TNE>
- [11] Connect Xbox One Kinect to PC Tutorial, available online: [https://www.youtube.com/watch?v=KZunnyw\\_RKQ](https://www.youtube.com/watch?v=KZunnyw_RKQ)
- [12] DIY Kinect Adapter with Disassembly for Xbox One S, X and PC, available online: <https://youtube.com/watch?v=71Q93qzqgo>