

Design of a Half-bridge (HB) LLC Resonant Converter



Zoran B Zivanovic, Vladimir J Smiljakovic
IMTEL KOMUNIKACIJE AD
Bul. Mihajla Pupina 165b
11070 Belgrade, Serbia
{zoki@insimtel.com} {smiljac@insimtel.com}

ABSTRACT: *We in this work have introduced the design of a half-bridge (HB) LLC resonant converter. We have described the operating principles including the functional block diagram. To test the system, we have developed pilot studies and made performance analysis and the results are presented to support the theoretical analysis and to demonstrate the converter performance.*

Keywords: HB, LLC, Resonant, Synchronous, ZVS

Received: 27 March 2021, Revised 30 June 2021, Accepted 7 July 2021

DOI: 10.6025/stj/2021/10/2/49-57

Copyright: Technical University of Sofia

1. Introduction

Growing demand for higher power density, higher efficiency and lower profile have resulted in increase of the frequency in switching power supplies. Operation at higher frequencies significantly reduces the size of magnetic components, such as transformers and chokes. On the other hand, switching losses are considerably higher at higher frequencies. To reduce the switching losses, resonant converters with zero voltage switching (ZVS) have been developed. ZVS means that voltage across the switch drops to zero before switch turns on. Focus was first on resonant square wave converters (phase shift full bridge) and recently on fully resonant converters with sinusoidal currents instead of trapezoidal currents. Fully resonant converters process power conversion with frequency modulation instead of pulse width modulation.

2. LLC Converter Basics

Simplified schematic of a half-bridge LLC resonant converter is shown in Figure 1. This is a type of series resonant converter that allows operation in a relatively wide input voltage range and output load range compared to other resonant topologies. The converter consists of four main sections: the square wave generator, the resonant circuit, the rectifier circuit and the feedback loop (not shown in Figure 1). The square wave generator generates square wave voltage by driving the power switches Q_1 and Q_2 with alternating 50% duty cycle for each switch. Of course, a small dead time is always introduced between successive transitions. For all normal load conditions, the power switches are in zero voltage switching condition. The resonant circuit consists of the resonant capacitor C_r , resonant inductor L_r and transformers magnetizing inductance L_m that acts as a shunt inductor.

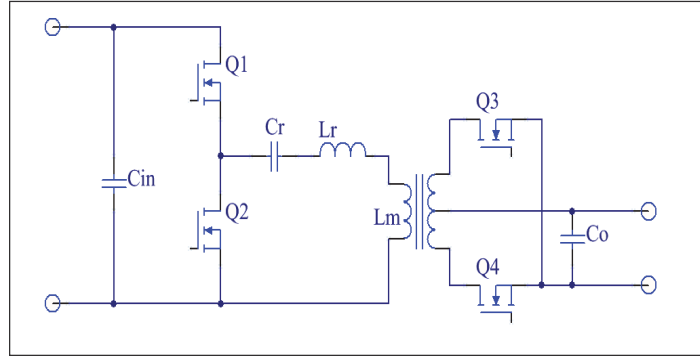

Figure 1. HB LLC converter

The magnetizing inductance L_m is three to eight times larger than the inductance of resonant inductor L_r . This is usually accomplished by introducing an air gap in the transformer. Operation frequency is near the resonant frequency determined by L_r and C_r . Because of that, the resonant circuit filters the higher harmonics of current produced by square wave voltage. Sinusoidal current lags the applied voltage which enables the ZVS condition for power switches. Sometimes it is practical to use the leakage inductance of the transformer as a resonant inductor, so that only one magnetic component is used. The resonant capacitor must be of high voltage type (over 600V). The rectifier circuit produces DC voltage by rectifying alternating current with diodes and capacitive output filter. Instead of diodes, for higher efficiency the synchronous rectifiers are used (power switches Q_3 and Q_4 as shown in Figure 1). The rectifier circuit is usually used in center taped configuration with two windings (as shown in Figure 1). For lower output currents the bridge configuration is used. In both cases, rectifier works in zero current switching condition. Feedback loop is similar to other topologies and the only difference is that it uses frequency variation to maintain the output regulation.

3. Design and Analysis

The goal is to design a half-bridge LLC resonant converter using CoolMOS MOSFETS for the primary power switches and OptiMOS MOSFETs for synchronous rectification. Achieving the efficiency over 90% is the primary objective. We will choose the switching frequency to be around 100 kHz, which is a compromise between efficiency and size. Good choice for the transformer and the inductor core are PQ cores.

We will use a discrete solution for the resonant circuit because in that case we can use any L_r and L_m value. This complicates insulation between primary and secondary windings, but lowers radiated EMI emission. Besides that, drawback is assembling of two magnetic components instead of one.

Design input parameters are given in Table 1.

		Min	Typ	Max	
Input voltage	V_{IN}	320	360	400	V
Output voltage	V_O	28			V
Output power	P_O	500			W
Full load efficiency	η	92			%
Resonant frequency	f_o	110			kHz

Table 1. Design Input Parameters

Starting from design input parameters we will now calculate basic parameters of the resonant circuit (Table 2) using Eqs. (1), (2) and (3).

$$n = \frac{V_{IN}}{2V_o} \tag{1}$$

$$m_{g_min} = n \frac{2(V_O + V_F)}{2V_{IN_max}} \quad (2)$$

$$m_{g_max} = n \frac{2(V_O + V_F)}{2V_{IN_min}} \quad (3)$$

		Min	Typ	Max
Transformer turns ratio	n		6.43	
Min. voltage gain	m_{g_min}	0.92		
Max. voltage gain	m_{g_max}			1.30

Table 2. Resonant Circuit Parameters

From peak gain curves given in Figure 2, we will select the point with $m_g = 1.55$, inductance ratio $L_n = 4$ and quality factor $Q_e = 0.4$.

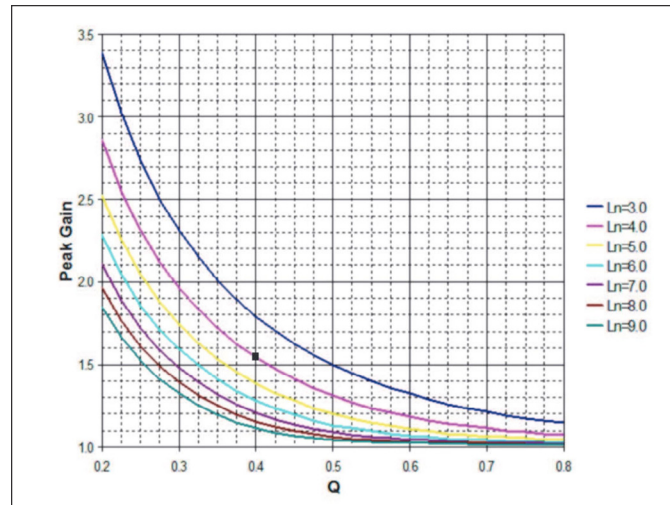

Figure 2. Peak gain curves

Now we can calculate resonant circuit components using the Eqs. (4), (5), (6), (7) and (8). The results are given in Table 3.

$$R_e = \frac{8n^2 V_O}{\pi^2 I_O} \quad (4)$$

$$C_r = \frac{1}{2\pi Q_e f_o R_e} \quad (5)$$

$$Q_e = \frac{1}{2\pi f_o R_e C_r} \quad (6)$$

$$L_r = \frac{1}{(2\pi f_o)^2 C_r} \quad (7)$$

$$L_m = L_n L_r \quad (8)$$

		Typ	
Equivalent load resistance	R_e	56	Ω
Resonant capacitor	C_r	66	nF
Quality factor	Q_e	0.383	
Resonant inductor	L_e	32	μH
Magnetizing inductance	L_m	128	μH

Table 3. Resonant Circuit Components

Transformer		Typ	
Primary inductance	L_p	128	μH
Number of prim. turns	N_p	19	
Number of sec. turns	N_s	3	
Primary RMS current	I_{PRMS}	3.4	A
Resonant RMS current	I_r	4.4	A
Secondary RMS current	I_{SRMS}	15.49	A
Core gap	s	0.55	mm

Table 4. Transformer Basic Parameters

Resonant inductor		Typ	
Inductance	L_r	32	μH
Number of turns	N	11.5	
RMS current	I_{RMS}	4.4	A
Core gap	s	0.65	mm

Table 5. Inductor Basic Parameters

For the primary winding of the transformer we will use triple-insulated bundle of 7 twisted wires with 0.3mm enamelled copper wires and for the secondary 0.2mm thick copper foil. For the inductor winding we will use simple 7 twisted wires with 0.3mm enamelled copper wires.

4. Realisation

The converter was built on two layer FR-4 substrate with $70\mu\text{m}$ copper with footprint $164\times 86\text{mm}$. The transformer and the resonant inductor are wound according to the calculations. For the primary switches we have used IPP50R299CP FETs (TO220 case) and for synchronous rectifiers BSC077N12NS3 FETs (TDSON-8 case). The output filter is made of 10 pcs of multilayer ceramic capacitors $10\mu\text{F}$, 35V, X7R. Using lab power supply 0-600V/8.5A and electronic load, we have recorded the waveforms at the points of the interest and measured efficiency at various loads.

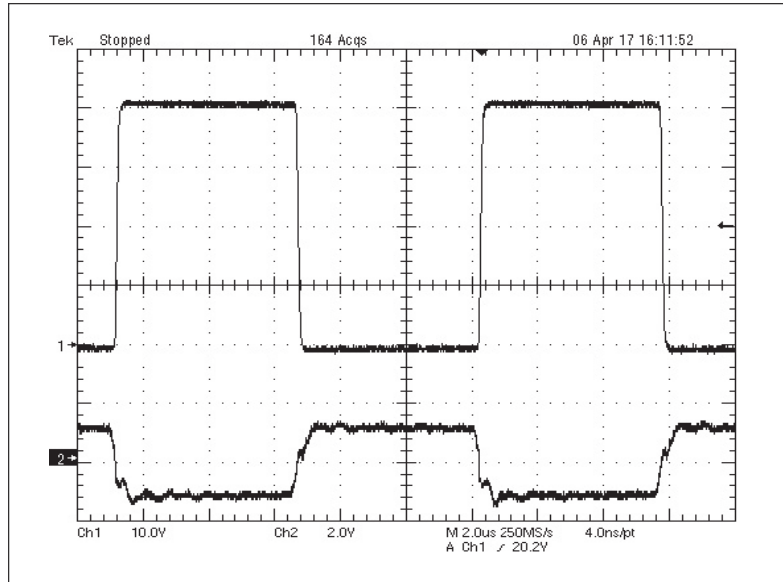

Figure 3. Drain and gate voltage of low side FET Q2

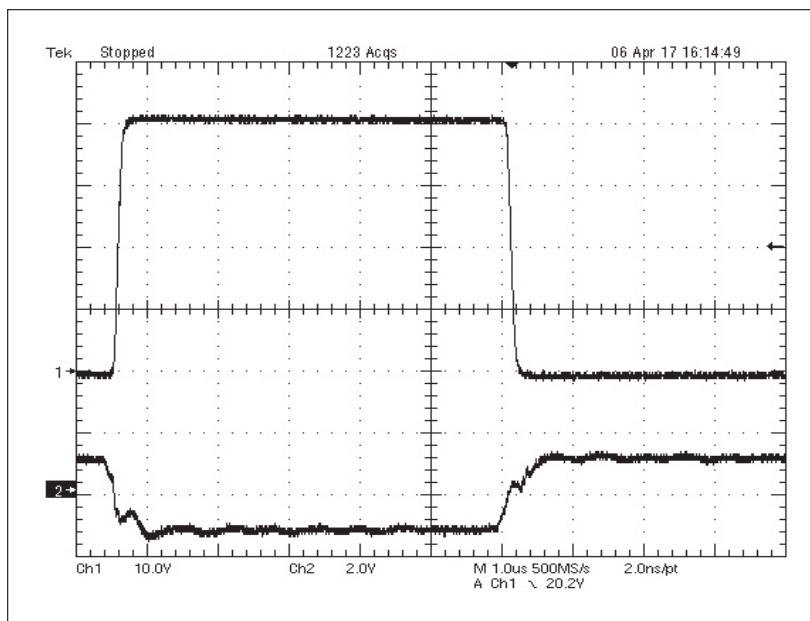

Figure 4. Drain and gate voltage of low side FET Q2 (zoomed in)

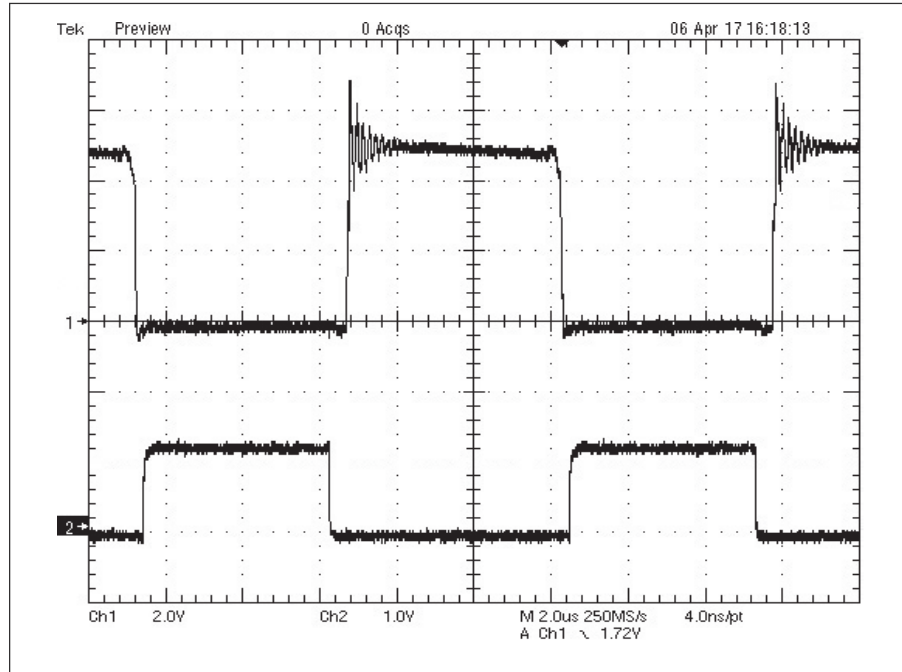

Figure 5. Drain and gate voltage of FET Q_4

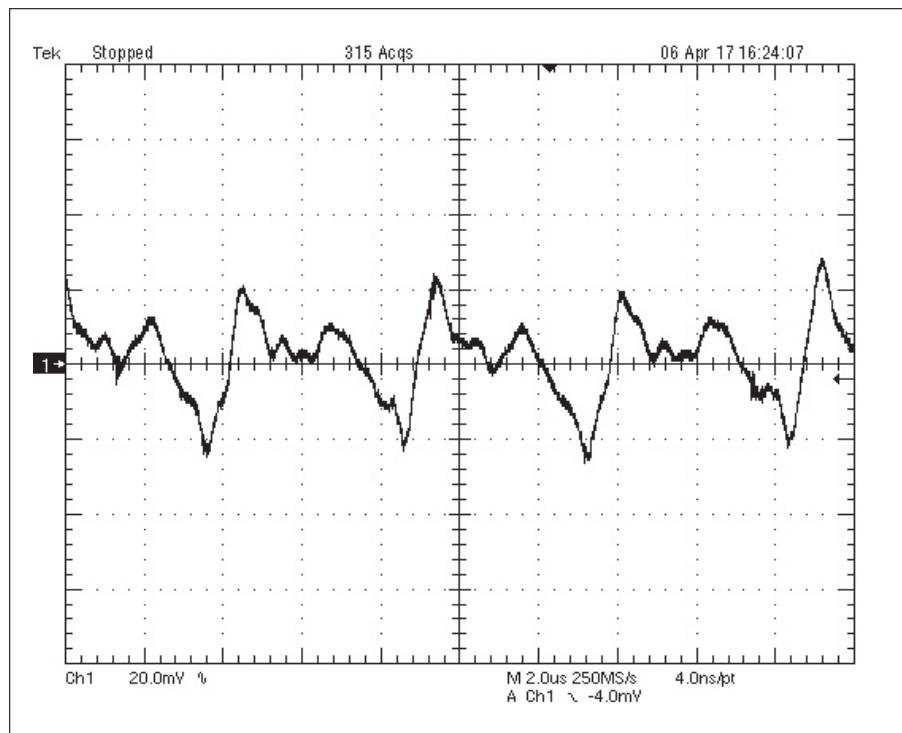

Figure 6. Output ripple at full load

5. Conclusion

In this paper the design and analysis of 500W half-bridge LLC resonant converter are presented. The prototype was built and tested. The results verified that the efficiency between 33% and 100% of load is over 94%.

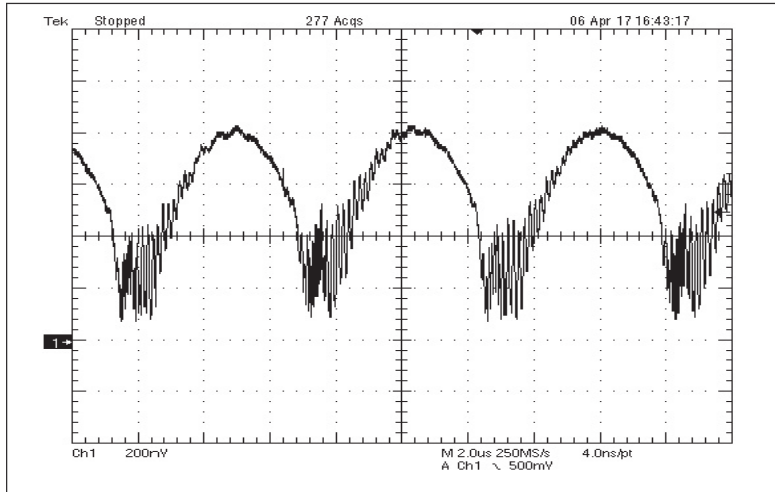

Figure 7. Primary current (rectified at current sense)

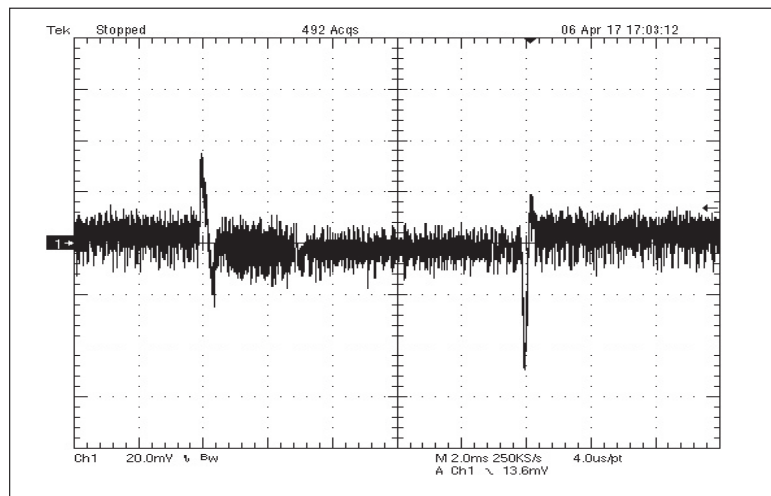

Figure 8. Output voltage load transient response

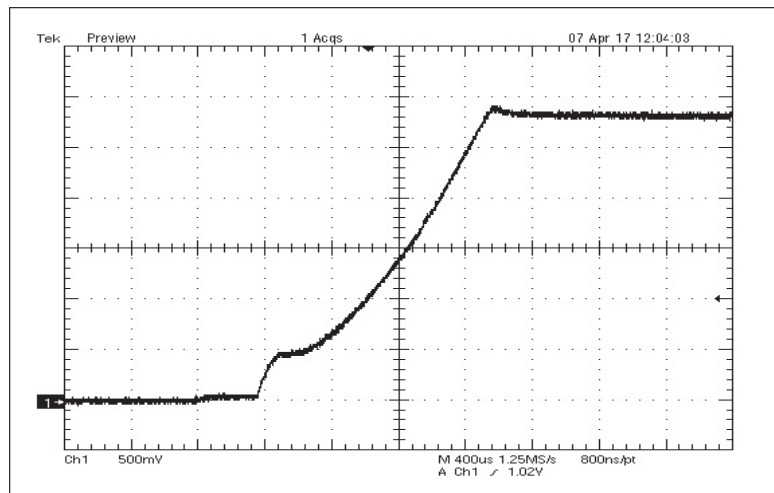

Figure 9. Output voltage rise into full load at turn on

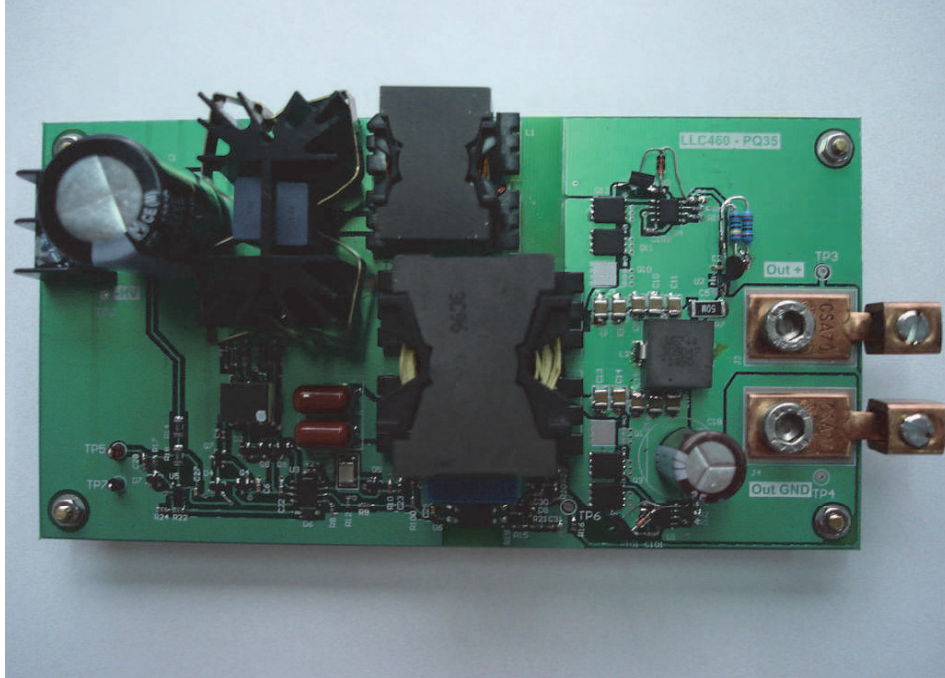

Figure 10. The converter prototype

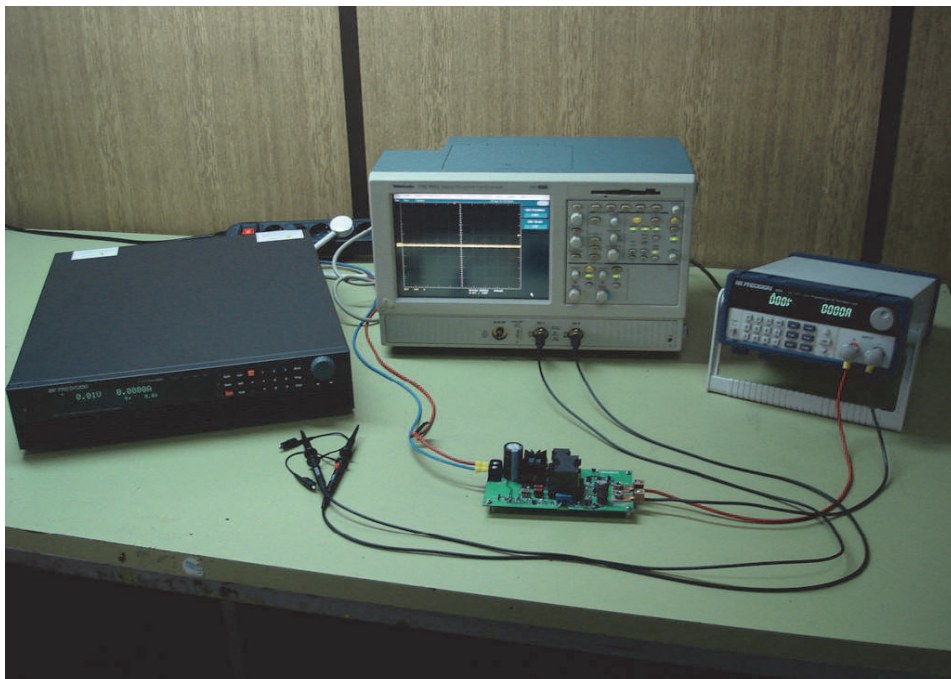

Figure 11. Experimental setup in the lab

Acknowledgement

The work is partially supported by the Serbian Ministry of Education and Science (Project III-44009).

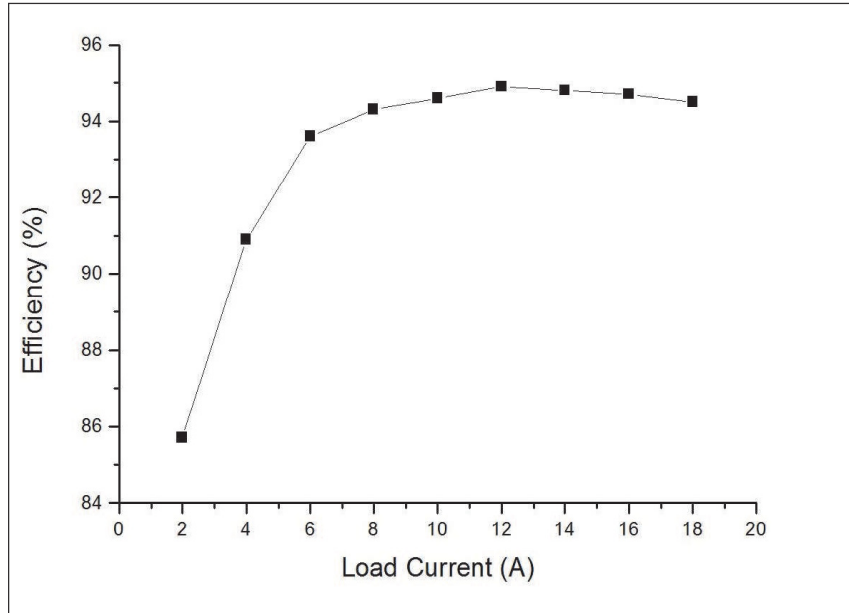

Figure 12. Efficiency vs. load current

References

- [1] Texas Instruments, UCC25600 8-Pin High-Performance Resonant mode controller, Data sheet, www.ti.com.
- [2] Ericsson, R.W., Maksimovic, D. (2001). Fundamentals of Power Electronics, Kluwer Academic Publishers, 2001.
- [3] Yang, B. (2006). Topology Investigation of Front-End DC/DC Converter for Distributed Power System, Ph.D. Dissertation, Virginia Tech, 2006.