

The Electrical Impedance Spectroscopy of Measurements



Svetlana Gerganova-Savova¹, Daniela Toneva-Zheynova² and Yanko Yanev³

¹Automation of Manufacturing Department Technical University of Varna, 1 Studentska str., Varna 9010, Bulgaria
gerganova-savova@lycos.com

²Dept. Ecology and Environmental Protection
Technical University of Varna
Varna, Bulgaria

³Automation of Manufacturing Department
Technical University of Varna, Varna, Bulgaria
yayanev@gmail.com

ABSTRACT: *To estimate the impedance, the electrical impedance spectroscopy is used in many areas and disciplines. We used the Randles model for presenting impedance measurement. The characteristics of the impedance systems are described further.*

Keywords: EIS-method, Randles Model, Soil Monitoring, Frequency Characteristics, Impedance

Received: 6 September 2021, Revised 20 December 2021, Accepted 9 January 2022

DOI: 10.6025/jio/2021/11/4/97-101

Copyright: with Authors

1. Introduction

The UN Standing Committee on Ecology defined environmental monitoring as a system of repeated observations on components and factors of the environment in spatially scale and consistently in time with specific purposes in accordance with monitoring programs [7]. Monitoring usually refers to processes in which observations are made over time and it is a special system for repeated observations and analysis of one or more elements of the environmental conditions, intended to register, evaluate and predict.

In the Bulgarian national system for environmental monitoring one the land - shaft, lands and soils are specific monitoring objects. The measurement generally refers to processes in which qualitative or quantitative properties are determined, as a rule. The main soil parameters, subject to measuring, with regard to soil contamination include: presence and concentration of heavy metals and metalloids, total nitrogen content (N_{tot}), nitrate nitrogen, ammonia, phosphorus, organic carbon, robust response of

the soil (pH), electrical conductivity, total carbon and persistent organic pollutants - 16 PAH, 6 PCB, 15 – chloro - organic pollutants, and others [6]. The needs of environmental monitoring, the frequency of sampling and measurement, allocations of sampling points and polygons, applied monitoring methodology should be determined correctly [8].

A wide variety of approaches and methods are applied in the soil monitoring systems, but most of the conventional methods for soil monitoring are direct, purely laboratory methods, expensive. Therefore, the use and maintenance of calibrated and verified tools for monitoring and measurement should be ensured, as well as the development and application of devices and software. The Electrical Impedance Spectroscopy (EIS-method) is a commonly adopted method in many areas and in practice it is used for the measurement of electrical resistance, also for obtaining the frequency characteristics of the impedance of porous materials, as is the soil. The method allows to create a profile of soils differing in composition, which shows the moisture content (moisture regain) and is indicative regarding mineral content and in some cases pollution level [2], [3].

The scheme of measurement can be depicted in the form of Figure 1 and it shows the equivalent scheme, originally proposed by John Randals (John Edward Brough Randles), for modeling of surface electrochemical processes [1], [4], [5]. Randals model is simple, while the real electrochemical systems are usually more complex, but it is the basis for more complex cases.

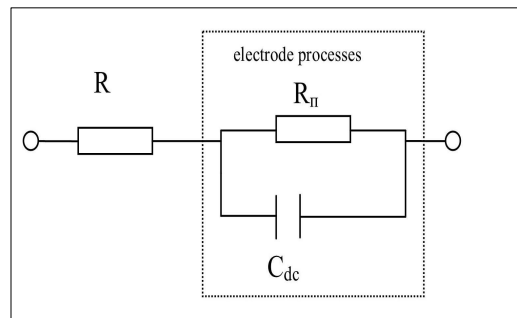

Figure 1. Randles model

where:

R - soil resistance [Ω],

R_{II} - polarization resistance [Ω],

C_{dc} - double layer capacity [F].

When the circuit has not only active but reactive elements as well, and the current is sinusoidal with circular frequency ω , then the Ohm's law can be generalized, and the participating variables become complex.

In the frequency domain the dependence for the impedance has the form:

$$Z(j\omega) = R + j\omega X \tag{1}$$

Frequency characteristics for Z can be written as complex numbers in algebraic form.

For the Impedance readings at Randals model is formed [5]:

$$Z = R + \frac{1}{\frac{1}{R_n} + \frac{1}{Z_{c_{dc}}}} \tag{2}$$

$$Z = \left(R + \frac{R_n}{1 + \omega^2 R_n^2 C_{dc}^2} \right) - j \frac{\omega R_n^2 C_{dc}}{1 + \omega^2 R_n^2 C_{dc}^2}$$

The frequency characteristics - real frequency, imaginary frequency, amplitude - phase characteristic, amplitude - frequency, a phase - frequency are calculated and analyzes regarding the purity of the soil.

For this purpose five measurements of different depths have been made on soils gathered from the North-Eastern regions of Bulgaria [3]. The measurements for the non-contaminated soil are at frequencies: 2000, 6000, 10000, 15000, 20000 Hz, at a temperature of the air 28 degrees , 25.6 degrees for the soil and a depth of 0-20cm and 40-60cm.

The measurements of the contaminated soil are made for the same frequency diapason of depths: 0-20cm, 20-40cm, 40- 60cm. They are processed in Matlab and some of the obtained results are systematized and presented below.

```
>>f=[2000,6000,10000,15000,20000]
```

```
>>ω= 2*pi* f
```

```
ω= 12560 37680 62800 94200 125600
```

```
>>Re1 =[1271,1268,1265,1260,1249]
```

```
>>Im1 =[-195,-101,-23,73,167]
```

```
>>Re2 =[890,909,909,909,901]
```

```
>>Im2 =[-188,-68,-9,65,131]
```

```
>>hold on
```

```
>>plot(Re1, Im1, 'b')
```

```
>>plot(Re2, Im2, 'r')
```

```
>>Re3 =[110,105,103,102,101]
```

```
>>Im3 =[-80,-35,-19,-6, 4]
```

```
>>Re4 =[96,91,90,89,88]
```

```
>>Im4 =[-60,-27,-15,-4, 5]
```

```
>>Re5 =[103,98,97,95,94]
```

```
>>Im5 =[-60,-28,-16,-5, 5]
```

```
>>plot(Re3, Im3, 'g—')
```

```
>>plot(Re4, Im4, 'c—')
```

```
>>plot(Re5, Im5, 'm—')
```

.....

.....

The results are presented in figure 1 and figure 2. The top two graphics are for clean soil. The bottom three graphics are for contaminated soil.

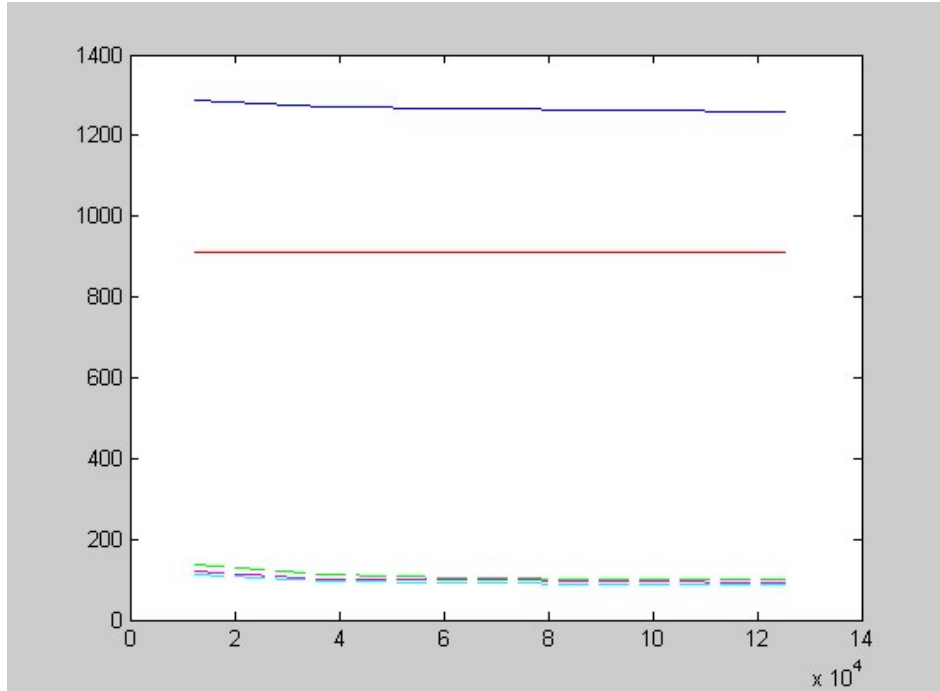

Figure 2. Amplitude – frequency characteristics

In figure 1 are presented amplitude – frequency characteristics.

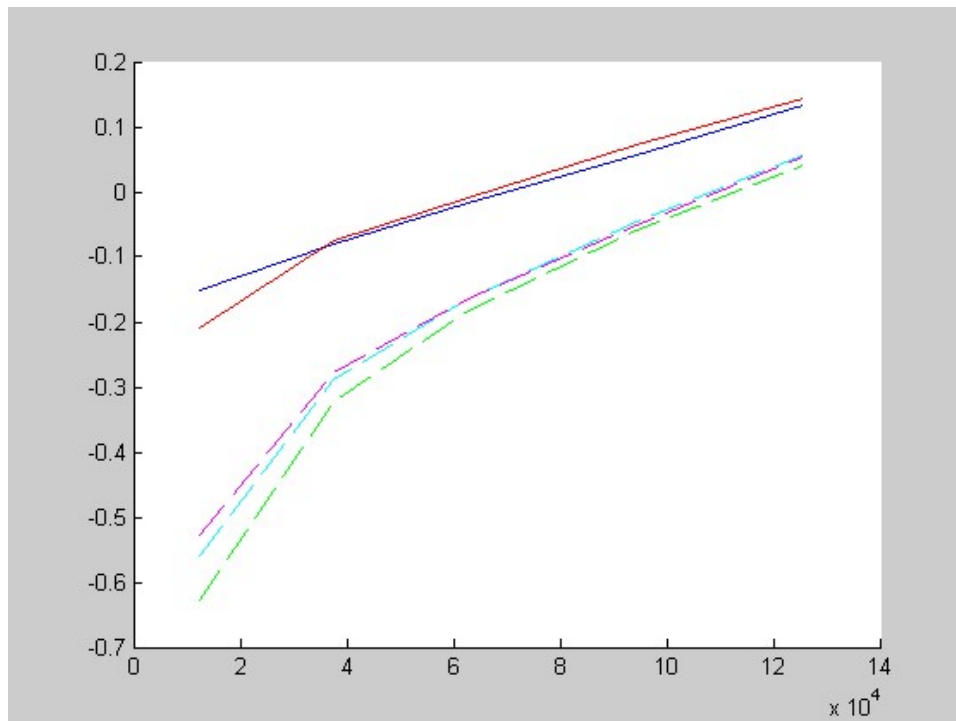

Figure 3. Phase – frequency characteristics

In figure 2 are presented phase – frequency characteristics. The graphics are presented in Matlab.

The frequency characteristics amplitude - frequency and phase - frequency of the clean and contaminated soil extract are substantially different - figure 2, figure 3. In rainy weather the soil has good conductive abilities, under certain chemical contaminants and in these cases $Z = (101-102) \Omega$. The soil contaminated with nitrates is a good conductor and the frequency characteristics are not affected by the depth of the probes, or by the frequency. The conductivity of water soluble electrolytes in the soil correlates with the concentration of the organic and micro organic elements. In terms of the environment increased levels of conductivity of the soil shows possible non-organic mineral pollution. The ammonium nitrate changes the electrical characteristics of the soil [4]. The graphics of the amplitude - phase characteristic are also indicative [5], that can be used with the same success.

Thus, by using the EIS method the content of fertilizer in the soil can be observed. This is especially important in the sanitary-protection zones of water catchments for drinking purposes, because the monitoring includes not only observation, but an assessment of the actual condition of the environment as well as forecasting its changes, and depending on the range, the tasks and directions. The purpose of monitoring is not only a passive observation of facts but also for conducting experiments, as well as process modelling as a basis for forecasting.

References

- [1] Янев Я., Д. Йонова, Относно използването на уреда Z-Meter III за изследвания по метода на електро импедансна спектроскопия, Годишник на ТУ-Варна, 2013г.
- [2] Parilkova J. Z-Meter III – User’s Manual, Brno 2011.
- [3] Toneva – Zheynova D., D. Ionova, A. Staneva, N. Atanasov, Application of EIS to environmental monitoring of soil, 2-nd Conference and Working Session within the Framework in the International Programme EUREKA, Brno, October 30-31, 2014.
- [4] Савова С., Д. Тонева-Жейнова, Мониторинг на почвата чрез измерване на електрическия импеданс и прилагането метода EIS, XXV национален научен симпозиум с международно участие "Метрология и метрологично осигуряване 2015", 357-362.
- [5] Toneva-Zheynova, D., Savova, S., Yanev, Y. (2015). Deming cycle and soil monitoring by Z-Meter III, EUREKA2015, 3-rd Conference and Work Session, Brno University of Tehnology, 109-114.
- [6] <http://eea.government.bg/bg/nsmos>
- [7] <http://razrobotkite.blog.bg/biznes/2010/09/16/monitoring-naokolnata-sreda-opredelenie-syshtnost.606632>
- [8] <http://www.iso.org/iso/home.html>