

# The Operational Conveyor System Based on the Steering Output Stage

Slobodan Djukic and Milan Veskovic  
Faculty of Technical Science Cacak University of Kragujevac  
Svetog Save 65  
32000 Cacak, Serbia  
{slobodan.djukic@ftn.kg.ac.rs} {Milan.veskovic@ftn.kg.ac.rs}



**ABSTRACT:** In this paper we have presented the operational conveyor system which depends on the steering output stage. We have performed the Wilson current mirrors to study the current precise distribution of the equal parts. We found that the suggested operational conveyor has very good voltage and current transfer characteristics, and has constant gain bandwidth product close to 2MHz. Moreover, the transistors with matched characteristics are not needed. The results of the simulation circuit with the PSPICE program are also presented in this study. The operational conveyor uses the standard electronic components and is suitable for the implementation in the integrated technics.

**Keywords:** Current-mode Processing Technique, Current Mirror, Current Conveyor, Operational Conveyor, Pspice Simulation

**Received:** 20 August 2021, Revised 18 November 2021, Accepted 30 November 2021

**DOI:** 10.6025/jes/2022/12/1/9-15

**Copyright:** with Authors

## 1. Introduction

The concept of the current conveyor (CCI) was introduced by Sedra and Smith, back in 1970. [1], and the possibility of its application in the implementation of the full-wave precision rectifier for the small signals is presented in the literature [2-5]. However, the area of application of the current conveyor is much broader. The symbol of the negative second type current conveyor (CCII-) is shown in Figure 1, and it can be mathematically described by the following matrix equation:

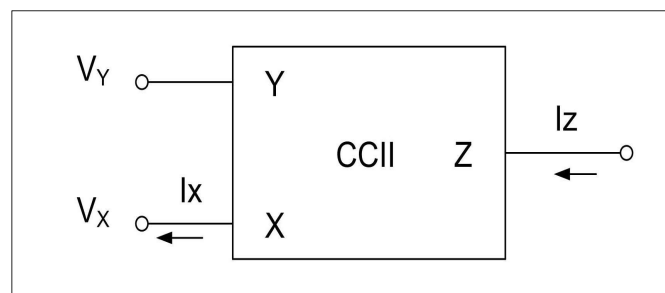

Figure 1. Symbol of the second type current conveyor (negative)

$$\begin{bmatrix} I_y \\ V_x \\ I_z \end{bmatrix} = \begin{bmatrix} 0 & 0 & 0 \\ 1 & 0 & 0 \\ 0 & \pm 1 & 0 \end{bmatrix} \cdot \begin{bmatrix} V_y \\ I_x \\ V_z \end{bmatrix} \quad (1)$$

or with three linear equations:

$$V_x = V_y, \quad (2)$$

$$I_y = 0, \quad (3)$$

$$I_z = \pm I_x. \quad (4)$$

The voltage signal  $V_y$  is connected to the high-resistance input  $Y$  and it buffers with the unity gain at the input  $X$  and the current  $I_x$  is mapped to the output  $Z$ . The problem is that the resistance  $r_x$ , which is recognized by the inverting input of the conveyor, is not zero. This resistance is small but it does not have a constant value and it affects the error of the voltage transfer function.

This current conveyor can be mathematically described by the following matrix equation [5]:

$$\begin{bmatrix} I_Y \\ V_Y \\ I_Z \end{bmatrix} = \begin{bmatrix} 0 & 0 & 0 \\ 1 & r_x & 0 \\ 0 & -1 & 0 \end{bmatrix} \begin{bmatrix} V_X \\ I_X \\ V_Z \end{bmatrix} \quad (5)$$

or with three linear equations:

$$I_y = 0 \quad (6)$$

$$V_Y = V_X = r_x I_X \quad (7)$$

$$I_Z = I_X \quad (8)$$

The concept of operational conveyor (OC) introduced by Gift [6] completely eliminates the resistance  $r_x$ , and it consists of the voltage operational amplifier (VOA), which works with the current conveyor (CCII) in a feedback loop, as shown in figure 2.

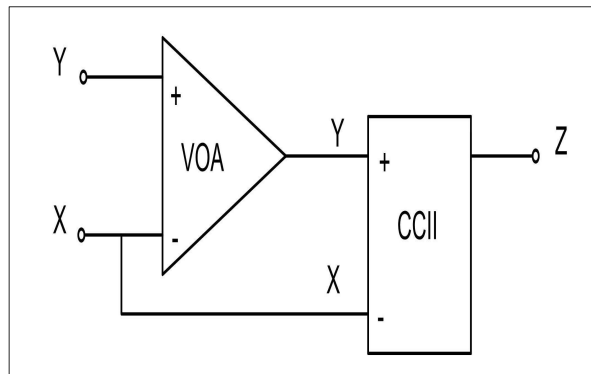

Figure 2. Operational conveyor with CCII used as a feedback circuit

The operational conveyor can be represented as a circuit with three connectors, as shown in Figure 3.

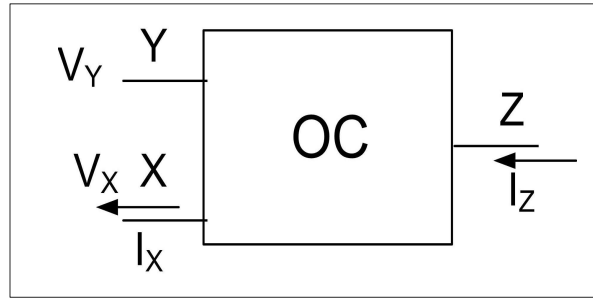

Figure 3. Symbol of the operational conveyor

Figure 4 shows the concept of the operational conveyor, with the voltage operational amplifier and current-steering output stage as the feedback circuit.

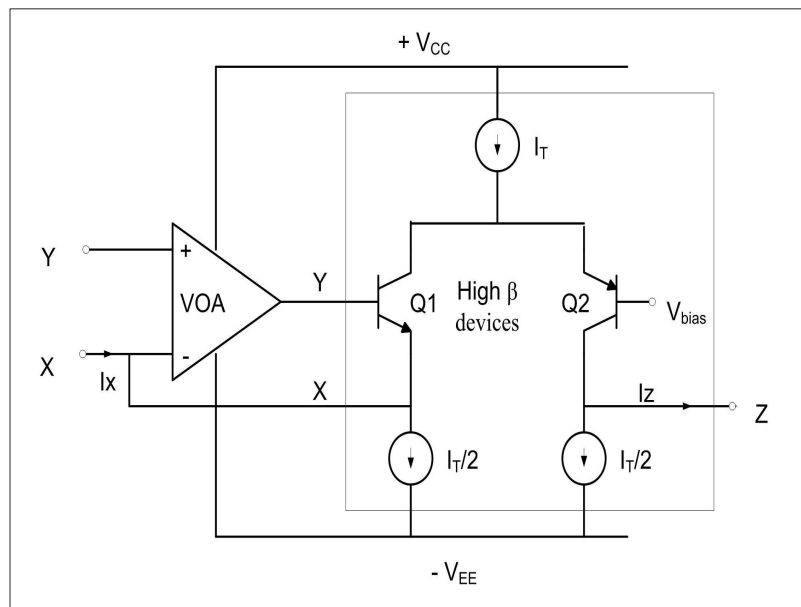

Figure 4. Operational conveyor with CCII used as a feedback circuit – basic formulation

Good voltage transfer characteristic between the terminals  $Y$  and  $X$  is provided by the usage of the negative feedback with the voltage operational amplifier. In order to keep the error in the voltage transmission function as small as possible, it is necessary that the current  $I_T$  is as higher, so that the input resistance of the transistor  $Q_1$  be smaller comparing to the output resistance of current sources. The increasing of the current  $I_x$  at port  $X$  for some amount causes the decrease of the current of the transistor  $Q_1$  by the same amount, which then causes an increase in current through the transistor  $Q_2$ , which causes an increase at the output for the same amount. The same can be concluded for the reduction of current  $I_x$ , so it can be concluded that the relation  $I_x = -I_z$  is valid. Transistors  $Q_1$  and  $Q_2$  should have a large current gain, in order to ensure the equality of their emitter and collector currents. It is important to notice that it is necessary to provide the exact division of the current  $I_T$  into two equal parts, which is not easy, given the fact that the current  $I_T$  should be variable. Figure 4 shows that in the feedback loop of the voltage operational amplifier there is a current conveyor. The question is whether the level of the current steering stage (bounded by rectangle) is in fact the current conveyor? The answer is positive, and for the following reasons:

- a) Its voltages  $V_x$  and  $V_y$  are roughly equal (they differ for the base-emitter voltage of the transistor  $Q_1$ )
- b) Its current  $I_y$  value is about zero because it is the transistor  $Q_1$  base current, and it has great current amplification,

c) It has already been demonstrated that the  $I_x = I_z$

### 2. Discrete Version of the Operational Conveyor Realisation

The complete scheme of the operational conveyor is presented in Figure 5. In relation to the literature [5], we performed the improvement in terms of the exact division of the current  $I_T$  into two equal parts using Wilson's current mirrors, but the current mirror of the unit amplifier can also be used [7]. The usage of discrete components requires their patient matching by their characteristics, although there are those ready-made components, such as CA3096AE (transistor arrays) [8]. To set the current  $I_T$ , the variable resistor  $R_2$  is used, and for the elimination of the offset voltage at the output terminal, the variable, resistor  $R_3$  is used. This is also an improvement as compared to the literature [8] because there is one resistor less.

### 3. PSPICE Simulation

In order to test the characteristics of the operational conveyor, it is presented as a voltage amplifier such as the excitation generator  $V_{in}$  is linked via the resistor  $R_{in}$  to the input  $X$  of the operational conveyor, and the  $Y$  connection to the ground, while the output  $Z$  through the load  $R_l$  is also connected to the ground. The supply voltages are  $V_{cc} = -V_{EE} = 5V$ , while the used transistors are 2n4014 (npn) and 2n4059 (pnp). Current amplification of the both transistor is approximately 180. For the value of the current  $I_T = 2mA$  the following values are used for the resistors  $R_2 = 4.6 k\Omega$  approximately. For the voltage operational amplifier we used TL082. The resistance  $r_x$  of such that it does not exist, or that the first matrix equation which describes its behavior is valid. We have made another simulation with uA741 and get little larger value for  $r_x$ .

Figure 6 shows the frequency dependence of the output impedance of the operational conveyor for the different values for the current  $I_T$ . It is noticed that it has a constant value (the order of magnitude of which in this case is in the order of a few tens of kilohertz size). Based on Figure 6 it can be concluded that the output impedance consists of the parallel connection of resistance and capacitance that can be seen at the port  $Z$  of the operational conveyor. It would be good if the magnitude of the output impedance module had as higher value as possible, which can be achieved by reducing the value of the set current  $I_T$ , but then the scope of the possible changes of the current  $I_z$  at the output, reduces, which is not good.

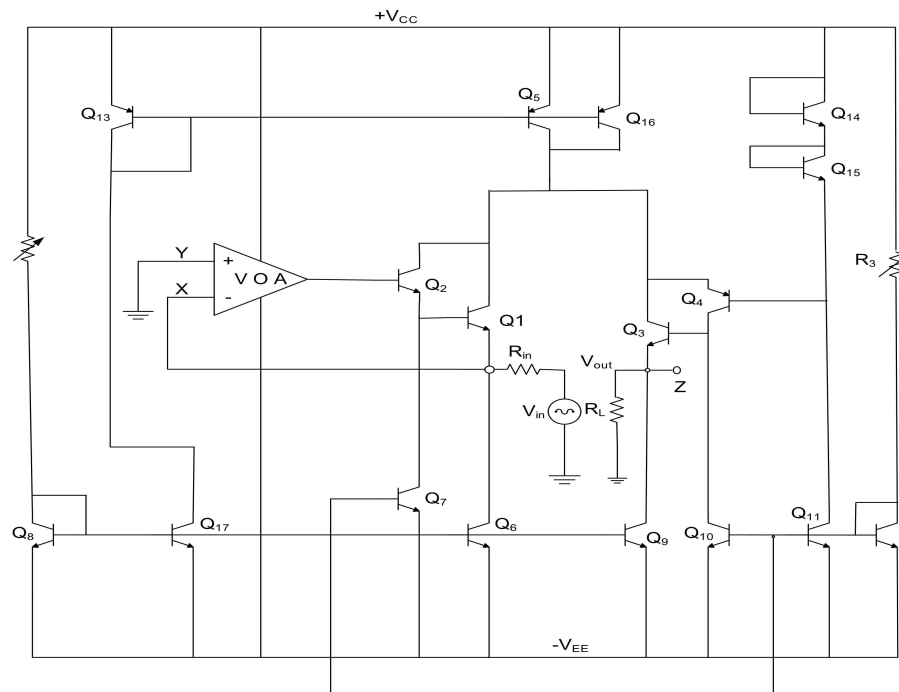

Figure 5. Discrete version of the proposed operational conveyor

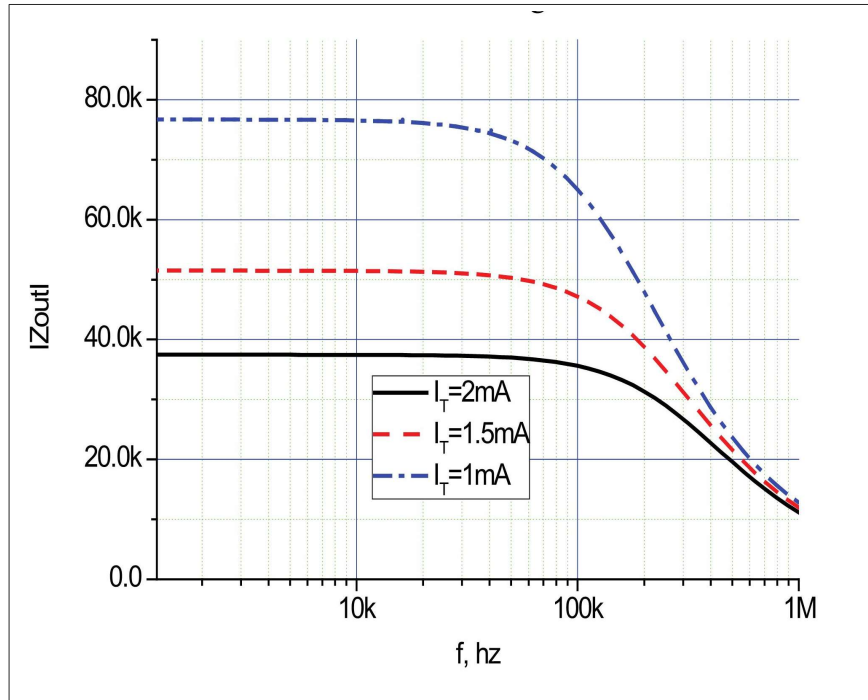

Figure 6. Output impedance curves of the operational conveyor for different current  $I_T$

Figure 7 shows the amplification of the operational conveyor in the function of frequency, based on which we conclude that the amplification change does not change the bandwidth range, and that the constancy of the product of the amplification and the bandwidth range does not apply to this operational conveyor.

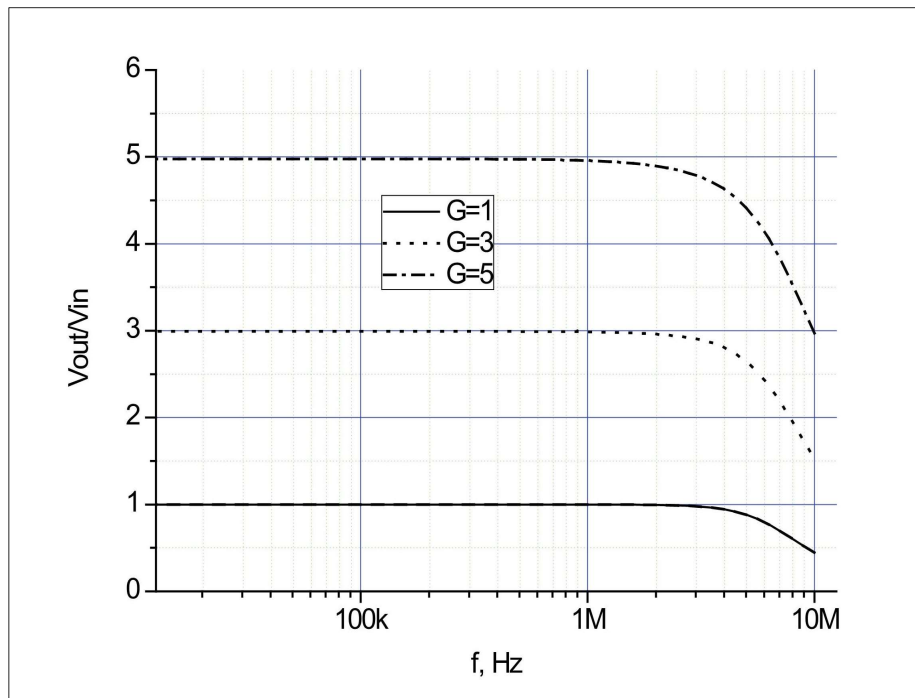

Figure 7. Frequency response of the operational conveyor for different gain  $G$

Figure 8 and Figure 9 show the current and voltage transfer function of the conveyor. It can be seen that the transfer characteristics of the observed ranges are practically ideal.

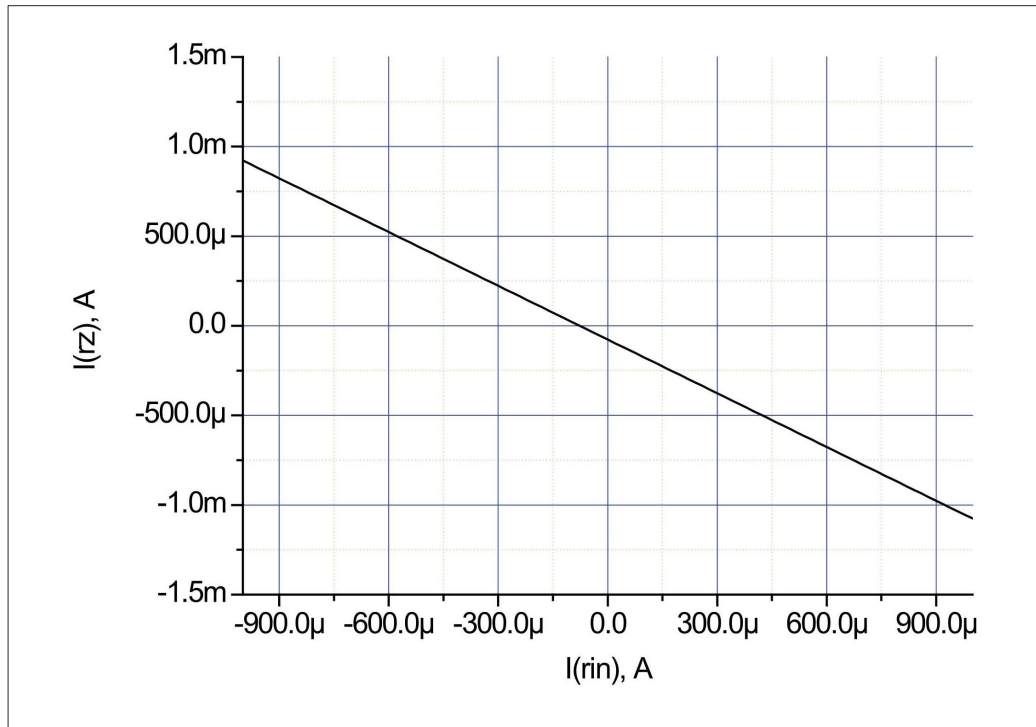

Figure 8. Current transfer characteristic of the operational conveyor

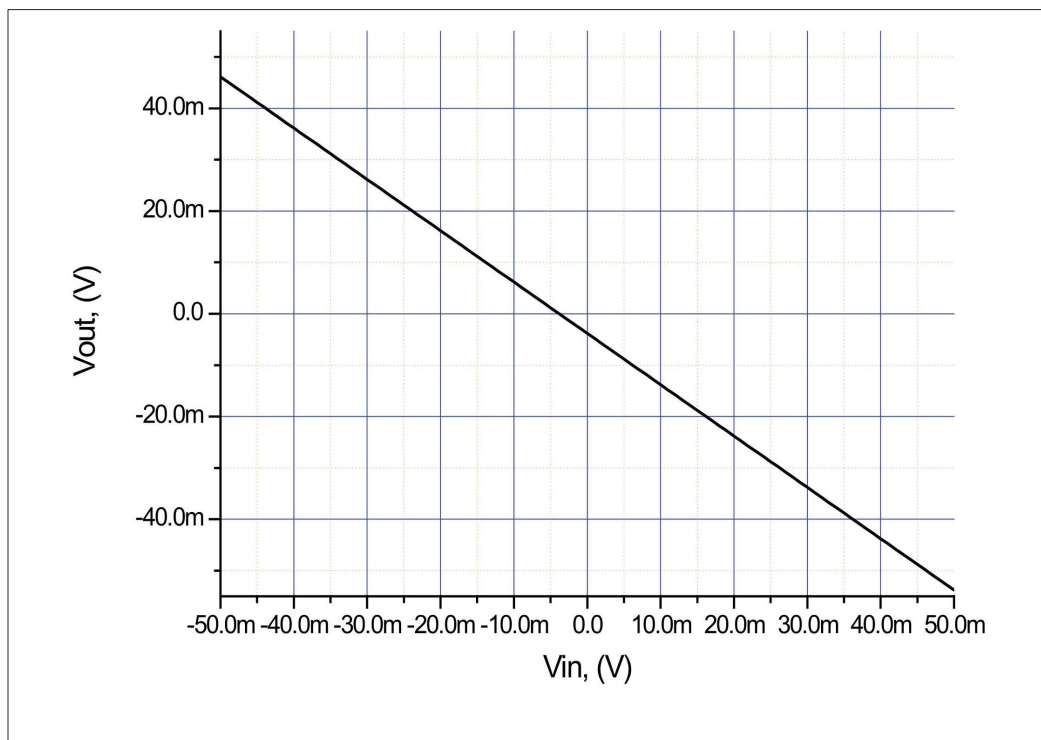

Figure 9. Voltage transfer characteristic of the operational conveyor

#### 4. Conclusion

The proposed implementation of the operational conveyor based on the current steering output and current mirrors, has excellent current and voltage transfer function, because a resistance at the inverting input of the operational amplifier has a negligible value. The transient behavior of that discrete version of the operational conveyor is very well-behaved, with a well-damped response giving a constant gain-bandwidth product close to 2 MHz. Limitation of the gain-bandwidth product is primarily caused by the  $f_T$  of the pnp transistors.

#### References

- [1] Sedra, A., Smith, K. C. (1970). A second generation current conveyor and its applications, *IEEE Trans. Circ. Theory*, CT – 17, 132 - 134.
- [2] Wilson, B. (1984). High-performance current conveyor implementation, *Electronics Letters*, 20, 990 - 991.
- [3] Djukic, R. S., Veskovic, M, Vulovic, A. (2010). An improved precision full-wave rectifier for low-level signal, 9<sup>th</sup> International symposium on electronics and telecommunications (ISETC), 33 - 38. DOI:10.1109/ISETC.2010.5679351., 2010.
- [4] Sahu P., Sing M., Baishya A. (2010). A Novel Versatile Precision Full-Wave Rectifier, *IEEE Transactions on instrumentation and measurement*, 59 (10) 2742 - 2746.
- [5] Al-Absi, Munir A. (2009). A novel highly accurate current mirror, *Int. J. of Electronics*, 96 (88) 781 - 786.
- [6] Gift, S.J.G., Maundy. Versatile Precision Full-Wave Rectifiers for Instrumentation and Measurement, *IEEE Trans. Instrumentation and measurement*, 56 (5) 1703 –1709.
- [7] Hart, B. L., Hayatleh, K., Lidgey, F. J. (2006). A new type of unitygain current-mirror, Circuits and Systems, Gatineau, Quebec, Canada, *IEEE North-East Workshop*, June, 89-92.
- [8] Wilson, B., Al-Gahtani, M., Vosper, J., Deloughry, R. (2006). High Precision Current Conveyor Implementation Employing a Current-Steering Output Stage, *Int. J. of Electronics*, 93 (10) 653 – 662.