

# Tools for Designing Double Squirrel Cage Routers

Blagoja Arapinoski<sup>1</sup>, Mirka P. Radevska<sup>1</sup>, Metodija Atanasovski<sup>1</sup> and Mile Spirovski<sup>1</sup>

<sup>1</sup>Faculty of Technical sciences at University of Bitola  
st. Makedonska Falanga 33, Bitola  
7000, Macedonia



**ABSTRACT:** *We in this work published the research on three-phase asynchronous motors which have inbuilt double squirrel cage rotor. Initially, we have developed tools that can help to design and analyse the electrical machines. This is possible by fixing the operation characteristics with ease. We have also presented equations relating to the operating characteristics for which we have used the tools. Experimentation with samples is organized with different loads and the outcome is presented with the help of tables and graphical displays.*

**Keywords:** Operating Characteristics, Three Phase, Asynchronous Motor with Double Squirrel Cage Rotor

**Received:** 19 January 2022, Revised 18 March 2022, Accepted 4 April 2022

**DOI:** : 10.6025/jitr/2022/13/3/57-62

**Copyright:** with authors

## 1. Introduction

The software package Ansoft - Maxwell 14 is specialized software designed for design and simulation analysis of electrical machines.[1]-[5] The concept of the program is so designed to enable continuous communication between the user and the computer at all stages of design, and it also enables the input of own creations and scientific knowledge by the user-designer. The program itself basically consists of three modules, interconnected:

The first module can design any electrical machine, calculate the parameters of the equivalent scheme that represents it, and determine all the performance characteristics in different modes of operation. In the database of this module, a large number of empirical equations from classical theory and part of the modern theory of electric machines are entered.

Designing and receiving a large number of results for the machine parameters, as well as the performance characteristics of different modes of operation in this module is very simple and fast.

As research subjects from which a portion is presented in the labor below, is selected three-phase asynchronous motor with double squirrel cage and with the following nominal data:

$$P_n = 3.5kW, U_n = 240V, f = 50Hz$$

$2p = 4$ ,  $\cos \varphi = 0.85$ ,  $\eta = 84\%$ , and  $\Delta$  winding connection.

## 2. Mathematical Model and Equivalent Replacement Scheme

The subject of the research is three phase asynchronous motor with double squirrel cage. As compared to the construction of the stator coil, the coil is identical to the standard three-phase asynchronous motors. The difference in this type of motor is in the rotor circuit, which are set two interconnected cages made of material with different conductance. The upper cage is known as start cage (used to run the electric motor when sliding is equal to 1), and is made of phosphor bronze alloy that has a lower conductivity compared to the bottom cage. The bottom cage is made of copper and has the role of the working cage when the speed of the rotor has a large enough value that scrolling is close to nominal. Currents redistribution from the top in the bottom cage is completely automatic and is dependent on the rotor speed and load.

The theory of asynchronous motors with double cage can be traced to the theory of three-phase three-winding transformers. That means double cages asynchronous motors can be considered as three separate electrical circuits that are magnetically coupled. The circuit indicated by I, represents the stator and circuit II, and III, representing the upper and lower cage rotor respectively. Each of these circuits respond appropriately active resistance  $R_I, R_{II}, R_{III}$  and inductance, respectively corresponding total inductive winding resistance  $X_I, X_{II}, X_{III}$ .

In asynchronous motors with double cage rotor, when the load changes, and changes in engine speed and thus the frequency of the current in the rotor-conductors, which causes a change of inductance and resistance in the rotor circuit. This phenomenon can be expressed mathematically in a way that the active component of the resistance of the rotor circuit is divided by sliding  $s$ , or simply if the rotor circuit of the upper and bottom cage add extra value to the active resistance  $R \frac{1-s}{s}$ . In that case we can write the following expressions:

$$\begin{aligned}\bar{U}_2' &= \bar{I}_2' R_2' \frac{1-s}{s} \\ \bar{U}_3' &= \bar{I}_3' R_3' \frac{1-s}{s}\end{aligned}\tag{1}$$

Voltage equations for this type of motor received form given by:

$$\begin{aligned}\bar{U}_1 &= \bar{I}_1(R_1 + jX_{\sigma 1}) - \bar{I}_2'(R_2' + jX_{\sigma 2}') - j\bar{I}_3'X_{\sigma}' - \bar{I}_2'R_2'\frac{1-s}{s} \\ \bar{U}_1 &= \bar{I}_1(R_1 + jX_{\sigma 1}) - \bar{I}_3'(R_3' + jX_{\sigma 3}') - j\bar{I}_2'X_{\sigma}' - \bar{I}_3'R_3'\frac{1-s}{s}\end{aligned}\tag{2}$$

Based on the previous expressions can be compiled equivalent electric scheme of asynchronous motor with double cage and is given on Figure 1.

## 3. Working Characteristics of Double Cage Three Phase Asynchronous Motors

The performance characteristics of the two-cages asynchronous motor are dependent on the output power  $P_2$ , the stator current  $I_1$ , the power factor  $\cos \varphi$ , the efficiency coefficient  $\eta$ , the slip  $s$ , the moment  $M$ , the speed of rotation of the rotor  $n$ , and the currents in the upper  $I_g$  and lower rotor cages  $I_p$ , and function of the consumed electric power  $P_1$ . The performance characteristics of the asynchronous two-phase motor can be obtained in several ways: Numeric with a computer program, which basically has an algorithm in which the equations connected with the aforementioned dependencies are added, Experimental obtaining of the working characteristics by direct method by reading the sizes and by an indirect method using a circular diagram. The software used for reconstruction of the calculation of the two-phase asynchronous motor provides the possibility of obtaining the operating characteristics in the numerical way mentioned above. Namely, the Ansoft- Maxwell 14 Rmxprt module calculates

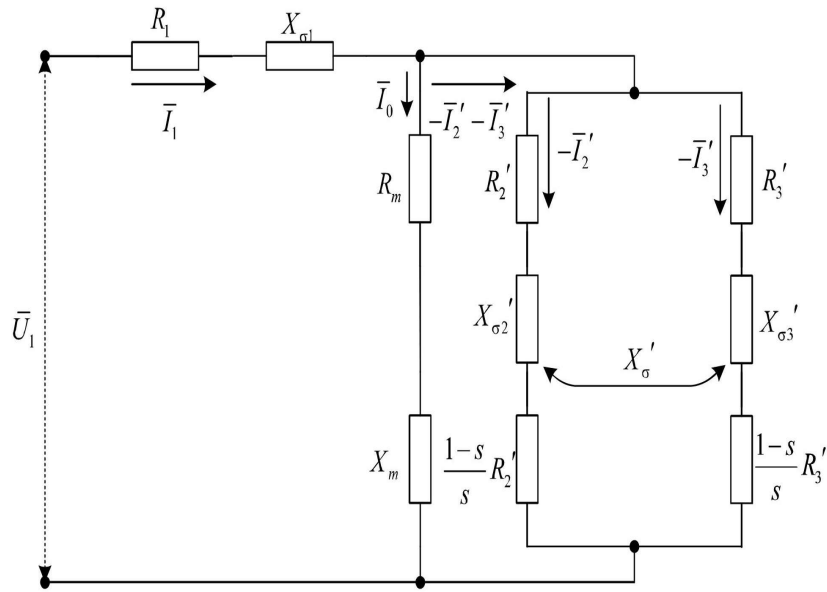

Figure 1. Asynchronous motor with double cage - equivalent electric scheme

and displays the performance characteristics of different motor operation modes, using a model programmed based on the equivalent dual cage-like asynchronous motor pattern.

Equations with which the working characteristics are obtained:

The current  $I_2''$  that flows into the rotor circuit of the motor reduced to a stator is given by the expression:

$$\bar{I}_2' = \bar{I}_2'' \cdot C_1 \quad (3)$$

The power factor of this current is given by:

$$\cos \varphi_2 = \frac{\left( R_1'' + \frac{R_{2e}}{s} \right)}{\bar{Z}_e}; \quad \sin \varphi_2 = \frac{\left( X_{\sigma 1}'' + X_{\sigma}'' + X_{\sigma 2e} \right)}{\bar{Z}_e} \quad (4)$$

For the active and reactive current in the rotor circuit, the following expressions are valid:

$$\begin{aligned} I_{2a}'' &= I_2 \cos \varphi_2 \\ I_{2r}'' &= I_2 \sin \varphi_2 \end{aligned} \quad (5)$$

The impedance in the branch of the magnetization is:

$$\bar{Z}_0 = \sqrt{(R_1 + R_m)^2 + (X_{\sigma 1} + X_m)^2} \quad (6)$$

The current of an ideal Idling, active and reactive component is calculated by:

$$\bar{I}_{0i} = \frac{\bar{U}_n}{\bar{Z}_0}; \quad I_{0a} = I_{0i} \cos \varphi_0; \quad I_{0r} = I_{0i} \sin \varphi_0 \quad (7)$$

Where the power factor is given by:

$$\cos \varphi_0 = \frac{R_1 + R_m}{Z_0}; \quad \sin \varphi_0 = \frac{X_{\sigma 1} + X_m}{Z_0} \quad (8)$$

The current that the motor takes from the network, i.e., the current flowing through the three-phase distributed stator winding is the vector sum of the currents from the ideal idling and the current flowing into the rotor circuit of the motor:

$$\bar{I}_1 = \sqrt{\left( I_{0a} + I_{2a}'' \right)^2 + \left( I_{0r} + I_{2r}'' \right)^2} \quad (9)$$

The actual value of the current flowing through the rotor circuit of the machine is:

$$\bar{I}_2 = \bar{I}_2' k_i \quad (10)$$

For the currents in the upper and lower cage of the rotor, the expressions are:

$$\bar{I}_g = \frac{\bar{I}_2}{\bar{Z}_g \left( 1 + \frac{\bar{Z}_d}{\bar{Z}_g} \right)}; \quad \bar{I}_d = \frac{\bar{I}_2}{\left( 1 + \frac{\bar{Z}_d}{\bar{Z}_g} \right)} \quad (11)$$

The power factor of the motor is given by:

$$\cos \varphi_1 = \frac{I_{1a}}{I_1}; \quad \bar{I}_{1a} = \bar{I}_{0a} + \bar{I}_{2a}'' \quad (12)$$

For the energy balance, that is, the power that the motor takes from the network and the losses that occur in it, the following expressions apply:

$$\begin{aligned} P_1 &= m_1 U_n I_{1a}; & P_0 &= m_1 (R_1 + R_m) I_0^2 \\ P_{cu1} &= m_1 R_1 I_1^2; & P_{cu2} &= m_1 R_{2e} I_2''^2 \\ \sum P_g &= P_0 + P_{cu1} + P_{cu2} + P_{men} \end{aligned} \quad (13)$$

The useful power of the motor axle is obtained when the total power losses in the motor are deducted from the input power:

$$P_2 = P_1 - \sum P_g \quad (14)$$

The coefficient of efficiency, the speed at which the rotor turns and the electromagnetic torque are calculated with the following expressions:

$$\eta = \frac{P_2}{P_1}; \quad n = (1-s)n_1 \quad (15)$$

$$M_{em} = \frac{pm_1 U_n^2 \frac{R_{2e}}{s}}{2\pi f_1 \left[ \left( R_1'' + \frac{R_{2e}}{s} \right)^2 + \left( X_{\sigma 1}'' + X_{\sigma}'' + X_{\sigma 2e} \right)^2 \right]} \quad (16)$$

#### 4. Obtained Results from the Simulation

The performance display in Ansoft Maxwell 14's Rmxprt can be tabular and graphical. Simulations were made to obtain the performance characteristics at different loads, i.e. 20 different operating modes were analyzed with the step of changing the sliding  $\Delta s = 0.2\%$ , and the results of the simulations are given in Table 1.

$s$	$P_1$ [W]	$P_2$ [W]	$I_1$ [A]	$\cos\varphi$	$\eta$	$n$ [min <sup>-1</sup> ]	$M$ [Nm]	$I_s$ [A]	$I_r$ [A]	$I_2$ [A]
0.001	416.3	32.8	2.12	0.27	0.0789	1498	0.846	4.95	1.85	6.75
0.003	681.3	295.2	2.26	0.42	0.4332	1495	2.523	14.65	5.52	20.17
0.005	943.9	552.5	2.45	0.53	0.585	1492	4.175	24.33	9.177	33.59
0.007	1203.9	804.6	2.69	0.62	0.668	1489	5.799	33.92	12.81	46.72
0.009	1460.7	1051.1	2.96	0.68	0.719	1486	7.395	43.42	16.39	59.81
0.011	1714.1	1291.6	3.25	0.73	0.753	1483	8.958	52.81	19.95	72.77
0.013	1963.5	1526.1	3.55	0.77	0.777	1480	10.48	62.19	23.48	85.56
0.015	2208.8	1754.1	3.87	0.79	0.794	1477	11.98	71.27	26.98	93.25
0.017	2449.7	1975.5	4.19	0.81	0.806	1474	13.44	80.31	30.44	110.76
0.019	2685.4	2190.2	4.51	0.83	0.815	1471	14.86	89.23	33.86	123.09
0.021	2917.1	2398.1	4.84	0.84	0.822	1468	16.25	98.81	37.25	135.23
0.023	3143.1	2598.8	5.16	0.845	0.826	1465	17.58	106.64	40.59	147.27
0.025	3363.7	2792.6	5.49	0.851	0.83	1462	18.88	115.13	43.91	159.03
0.027	3578.8	2979.3	5.81	0.856	0.832	1459	20.15	123.46	47.17	176.63
0.029	3788.4	3158.8	6.12	0.859	0.833	1456	21.36	131.62	50.41	182.84
0.031	3992.2	3331.3	6.44	0.861	0.834	1453	22.54	139.66	53.58	193.25
0.033	4190.3	3496.7	6.75	0.862	0.8345	1450	23.67	147.52	56.78	204.26
0.035	4382.4	3635.1	7.06	0.8626	0.835	1447	24.77	155.23	59.88	215.06
0.037	4568.8	3806.1	7.36	0.863	0.833	1444	25.82	162.76	62.91	223.65

Table 1. Results of the calculations for obtaining the performance characteristics

The results of the calculated currents in the stator and the rotor rings are significant because they can serve as input data for the load in the three-dimensional electromagnetic analysis with finite element method.

For good visibility, the performance characteristics are calculated and displayed graphically on one diagram in the relative units in Figure 2:

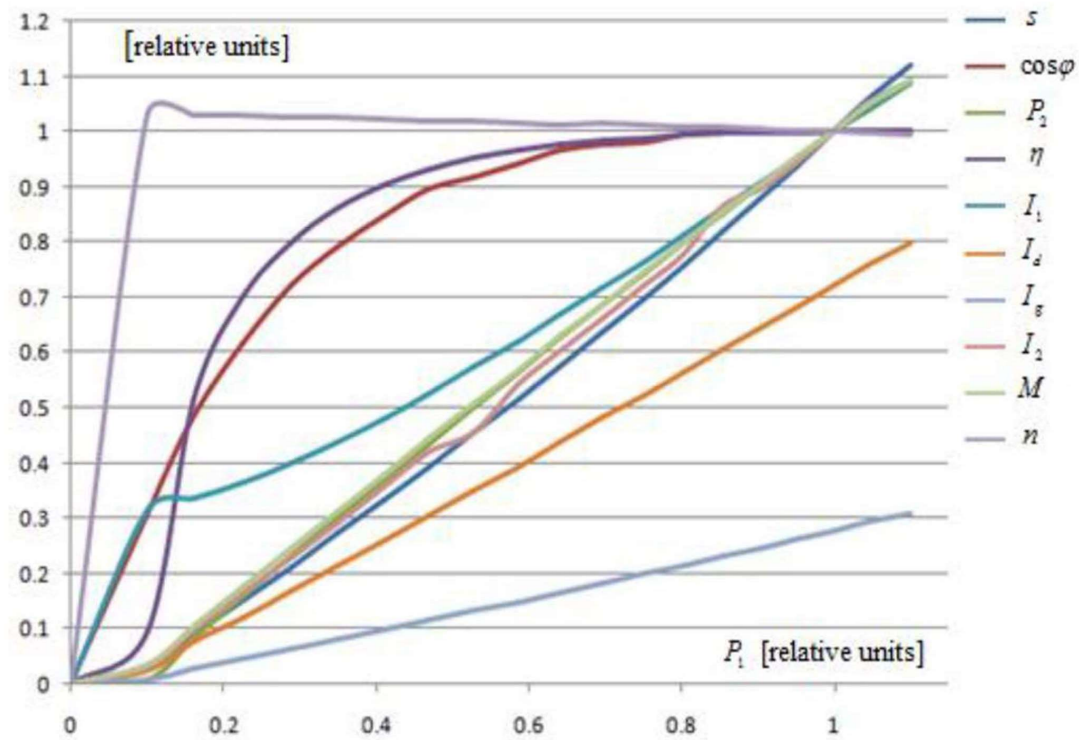

Figure 2. Operating characteristics of an asynchronous motor with a double cage

## 5. Conclusion

Designing with the (Rmxprt) Ansoft Maxwell 14 module is simple and at the same time gives excellent results when calculating the parameters of the equivalent electrical scheme and obtaining the operating characteristics for different operating modes. By comparing the calculated parameters with the help of analytical methods and numerical calculated parameters of the asynchronous motor with a double cage with the software used, the reliability of this kind of design is confirmed. Comparing the working characteristics obtained with the software and those of the experimental testing and in this respect, it confirms the accuracy and the possibilities.

## References

- [1] Popnikolova-Radevska, M., Cundev, M. & Petkovska, L. From macroelements to finite elements generation for electrical machines field analyses, *ISEF International Symposium on Electromagnetic Fields in Electrical Engineering*, Thessaloniki, Greece, 1995, p.p 346–349.
- [2] Popnikolova, M. (2006). Radevska: ‘Calculation of Electromechanical Characteristics on Overband Magnetic Separator with Finite Elements’, *ICEST2006*, p.p. Vols. 367–370. Sofia.
- [3] Arapinoski, B. & Popnikolova, M. (2010) Radevska. Electromagnetic and Thermal Analysis of Power Distribution Transformer with FEM’, 10th international conference of applied electromagnetic HEC 2011, Nis, Serbia, 2011. ICEST: Ohrid, Macedonia, R.Macedonia 2010. *Computation of solid salient poles synchronous motor electromagnetic characteristic*.
- [4] Mirka Popnikolova Radevska, Blagoja Arapinoski. (2011). Computation of solid salient poles synchronous motor electromagnetic characteristic, *10th international conference of applied electromagnetic HEC 2011*, Nis, Serbia, 2011.
- [5] Arapinoski, B., Radevska, M., Ceselkoska, V. & Cundevl, M. (2013) Modeling of three dimensional magnetic field in three-phase induction motor with double squirrel cage. *TEM Journal*.