

# Energy Reduction with Distributed Control Systems

Visa Tasic<sup>1</sup>, Marijana Pavlov-Kagadejev<sup>2</sup>, Rados Jeremijic<sup>3</sup>, Vladimir Despotovic<sup>4</sup>, Olivera Tasic<sup>5</sup>, Ivana Stojkovic<sup>6</sup>

<sup>1</sup>Mining and Metallurgy Institute Bor, Department of Science, Zelene bulevar 35, 19210 Bor, Serbia  
[visa.tasic@irmbor.co.rs](mailto:visa.tasic@irmbor.co.rs)

<sup>2</sup>Mining and Metallurgy Institute Bor, Department of Industrial Informatics, Zelene bulevar 35, 19210 Bor, Serbia  
[marijana.pavlov@irmbor.co.rs](mailto:marijana.pavlov@irmbor.co.rs)

<sup>3</sup>Dielectric DOO, Dr Milovanovica 15, 19210 Bor, Serbia  
[radosh2009@gmail.com](mailto:radosh2009@gmail.com)

<sup>4</sup>University of Belgrade, Technical Faculty in Bor, Vojske Jugoslavije 12, 19210 Bor, Serbia  
[vdespotovic@tf.bor.ac.rs](mailto:vdespotovic@tf.bor.ac.rs)

<sup>5</sup>Mechanical and Electrical High School Bor, Zelene bulevar 24, 19210 Bor, Serbia  
[oliverina.posta@gmail.com](mailto:oliverina.posta@gmail.com)

<sup>6</sup>University of Niš, Faculty of Electronic Engineering  
Aleksandra Medvedeva 14, 18000 Niš, Serbia  
[ivana.stojkovic@elfak.ni.ac.rs](mailto:ivana.stojkovic@elfak.ni.ac.rs)



**ABSTRACT:** Efforts are being made by people to reduce the electricity consumption as the world is moving towards energy reduction. For energy consumption reduction, the low-cost distributed control system is advocated in this paper. For an effective control system, a few elements such as new transducers, microcontrollers and communication models can be optimized. For this application we have used a control algorithm which is an integral part of the proposed distributed control system. Initially we plan to apply it in the ventilation system for testing the efficiency of the energy reduction system.

**Keywords:** Low-cost, Control, Electricity, Consumption

**Received:** 12 March 2022, Revised 28 May 2022, Accepted 19 June 2022

**DOI:** 10.6025/ed/2022/11/2/27-34

**Copyright:** with Author

## 1. Introduction

Department of Industrial Informatics, at the Mining and Metallurgy Institute Bor (MMI Bor), Serbia, has a long tradition in designing of the real-time DCS for monitoring and control of the industrial processes and electricity consumption [1-5].

The objective of electricity consumption control is to avoid exceeding one or more specified chargeable demand setpoints. This

means that energy must be limited to a fixed value. In this way, the optimization system actually limits the amount of imported energy during high demand measuring periods by shutting down certain power consumers, which is then compensated in the subsequent period. In order to determine which power consumers can be shut down at the specified point of time an extensive analysis must be conducted. Also, the constant and reliable communications between the elements of such DCS are of the critical importance. That is the reason why network nodes and segment building have to be carefully planned.

Most of our previously realized systems for electricity consumption control are based on the transformer substations control level (cells level). In order to make the DCS system cheaper, but also to be applicable to almost all consumers, we decided to install cheaper components (transducers, controllers, communication modules, etc.). The new DCS should satisfy the requirement that the measurement accuracy remains unchanged in relation to previously implemented systems (accuracy class 1). Such DCS use low-cost devices for the measurements, acquisition and data transfer. The proposed low-cost DCS can be easily applied for the control of electricity consumption for almost all types of electricity consumers. The elements of realized and implemented lowcost DCS will be presented in the sequel.

## 2. DCS Hardware

### 2.1. Power and Current Transducers

The basic elements of each DCS for electricity consumption control are power and current transducers that adjust electrical signals for further processing and transmission. Different types of measuring transducers have been recently developed for measurement of the electrical power and current of consumers.

Examples of the realized printed circuit boards of such devices are shown in Figure 1 and Figure 2. The power transducer (shown in Fig. 1) gives the standard voltage (0-5V DC) or current signals (4-20 mA) at the outputs, proportional to the active and reactive electric power at input, with less than 1% nonlinearity (using Aron measuring methods).

The current transducer (Figure 2) gives the standard voltage (0-5V DC) signal as an output, proportional to the input electric current, with less than 1% nonlinearity.

### 2.2. PLCs and Microcontrollers as DCS Network Nodes

Output signals from the power or current transducers are connected to the inputs of the PLC or microcontroller that serves both as data logger and DCS network node.

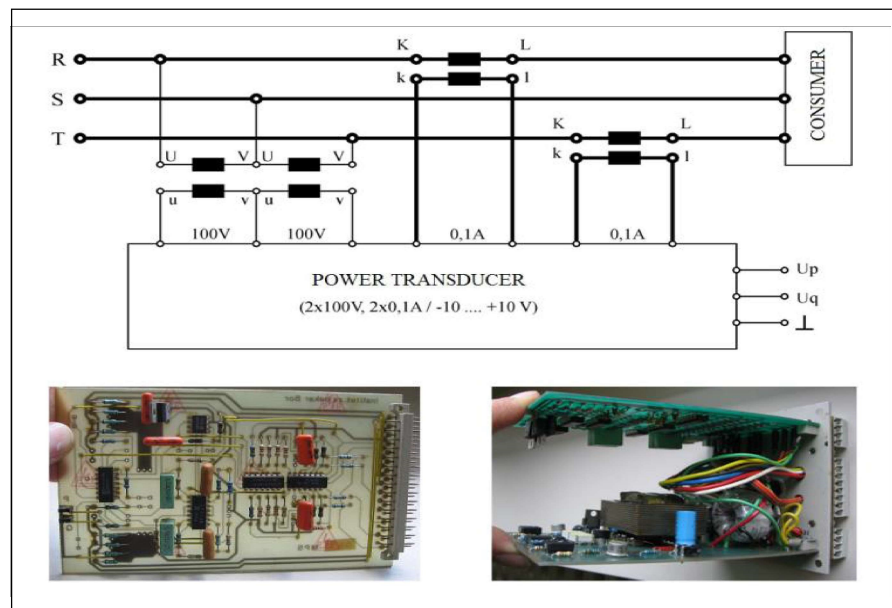

Figure 1. The principle of power transducer connection to the electric grid with the realized printed circuit boards of transducer

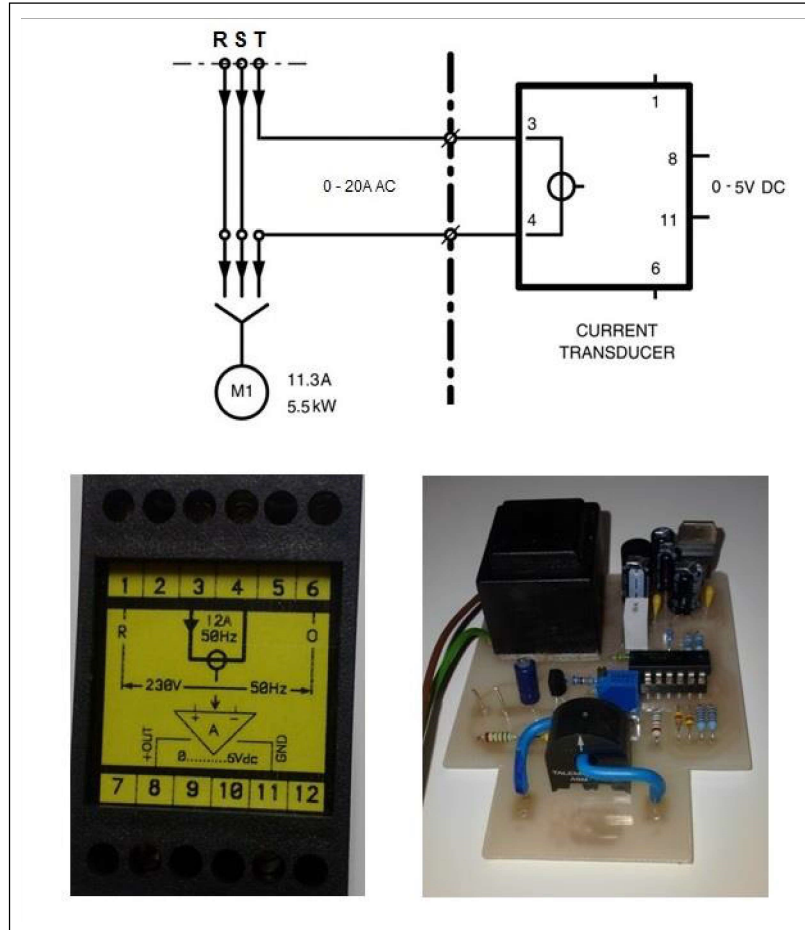

Figure 2. The principle of current transducer connection to the electric grid with the realized printed circuit boards of transducer

In the case of local control, as a result of processing the input signals the controller will generate the appropriate control signal based on the control algorithm. When it comes to implementing more complex management algorithms, i.e. when the controller is a DCS node, then the measurement results are passed to the decision-making DCS node. From the control level of DCS the commands are transferred back to the DCS nodes. So that, reliable communications between the DCS nodes are very important for it's functioning.

The Portable Measuring Station (PMS) and Universal Measuring Station (UMS) devices has been used as a core DCS nodes in the earlier realizations of DCS [3, 5].

In order to add new functionality to already existed DCS nodes, the interface module with the Arduino Mega 2560 microcontroller was realized. This board is shown in Fig 3. We chose the Arduino Mega because the language for its programming is similar to the C language. Further, because Arduino Software IDE is an open source environment and free. Also, the existing experiences we had in working with the Arduino platform indicated that this is an extremely stable platform. Finally, the Aduino Mega microcontroller was chosen because it's cheap, and has enough analogue and digital inputs and outputs for planned applications.

Arduino Mega 2560 microcontroller has 54 digital input/output pins (of which 15 can be used as PWM outputs), 16 analog inputs, 4 UARTs (hardware serial ports), a 16 MHz crystal oscillator, a USB connection, a power jack, an ICSP header, and a reset button [6]. When Arduino board serve as an UMS CPU (shown in Fig 4.), then a DCS network node is provided that can receive up to 64 analog inputs (0-5V DC), 64 digital inputs, and 32 digital outputs.

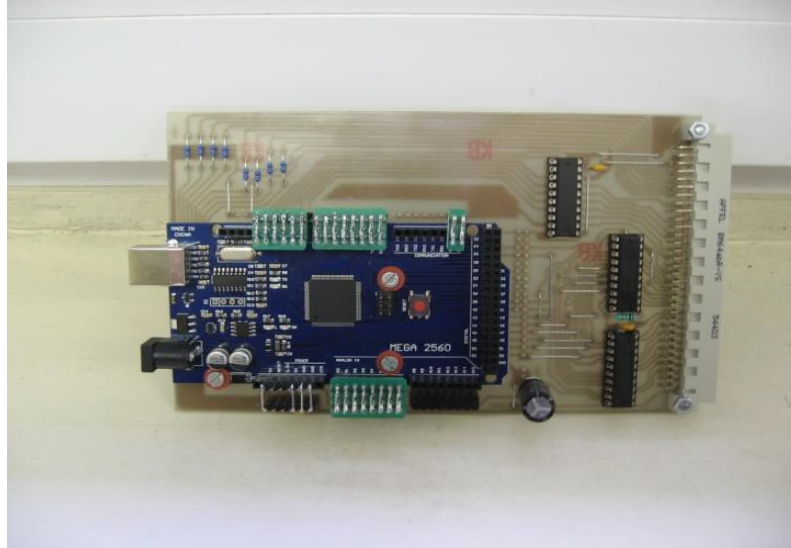

Figure 3. Arduino Mega 2560 interface board

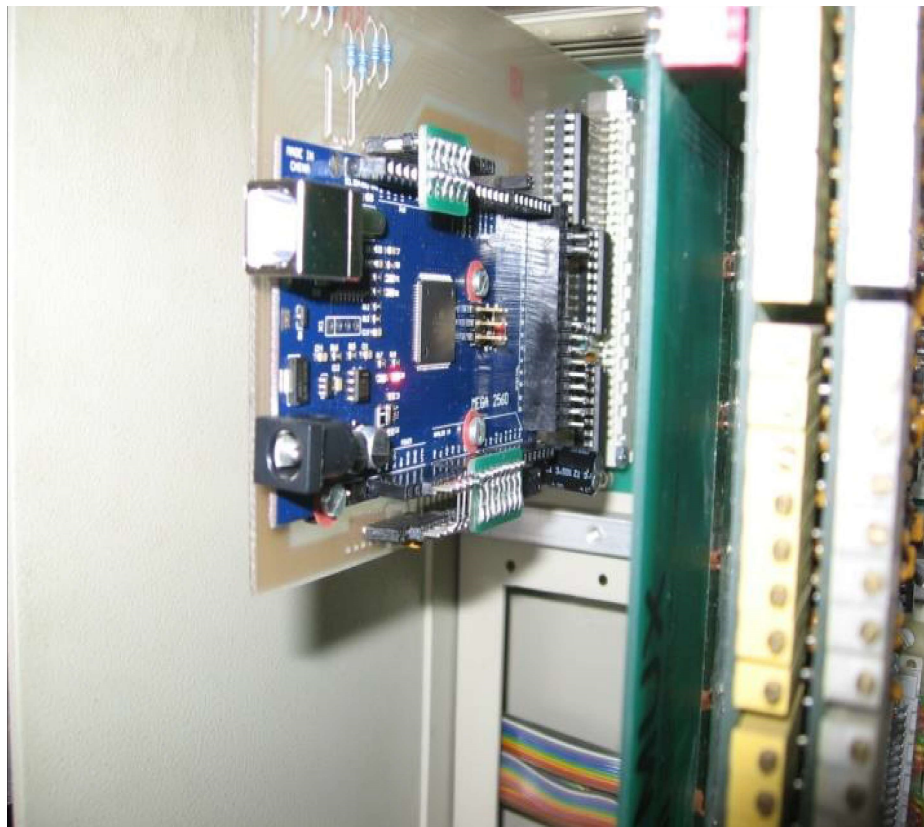

Figure 4. DCS node with an Arduino Mega board used as UMS CPU

The Arduino Mega interface board can be used as a DCS network node. In order to ensure efficient connection of the Arduino Mega board with other DCS nodes, additional modules, so-called shields, can be used. Fig 5. shows the Arduino Mega board with the GSM module attached (Arduino SIM800C Module).

The Arduino GSM shield allows an Arduino based board to connect to the Internet, and send and receive SMS, using the GSM library.



Figure 5. Arduino Mega interface board with the GSM module attached (Arduino SIM800C Module)

Expanding the functionality of DCS system demanded the installation of new transducers and controllers. All output signals from the different type of transducers can be connected either to the UMS inputs or to the Arduino Mega interface board inputs. Also, since the most of DCS nodes and other elements were dislocated, they have to be connected into the single DCS network.

### 2.3. DCS Control and Interaction Nodes

DCS network can be consisted of several dislocated segments. PC workstations are DCS control and interaction nodes. Depending on the control algorithms, such PC workstations can manage parts of the DCS system, or be subordinated to a single central workstation.

## 3. DCS Software

### 3.1. DCS Node Software

As it was described in the previous session, in order to obtain a low-cost DCS node, an Arduino Mega board was used, either as UMS CPU or as stand-alone DCS node. Arduino Software (Integrated Development Environment - IDE) is an open source environment that was used for writing the control programs that provides data acquisition, communication (USB, Ethernet, and wireless) and control actions [7].

Arduino platform is chosen as a node of DCS because it has shown good stability over time, so that, it has been frequently used in a many Wireless Sensor Network (WSN) projects.

### 3.2. DCS PC Workstation Software

Supervising Control and Data Acquisition (SCADA) realtime application, named Process Control Program (PCP) [8], is upgraded in order to support novel DCS elements and control principles (shown in Fig 6.).

PCP is developed using Microsoft Visual C++ [9]. It is based on a client/server architecture running on PC workstations. PCP enables integration of the DCS network nodes in a complex DCS network. It has a complex structure and consists of several modules.

Main program modules are designed for communication with DCS nodes, real-time data processing and presentation, interaction with DCS nodes according to the appropriate algorithm, reporting, data archiving, off-line data processing and database management. Interactions with the electricity consumers are performed according to the control algorithms considering the actual values of power consumption.

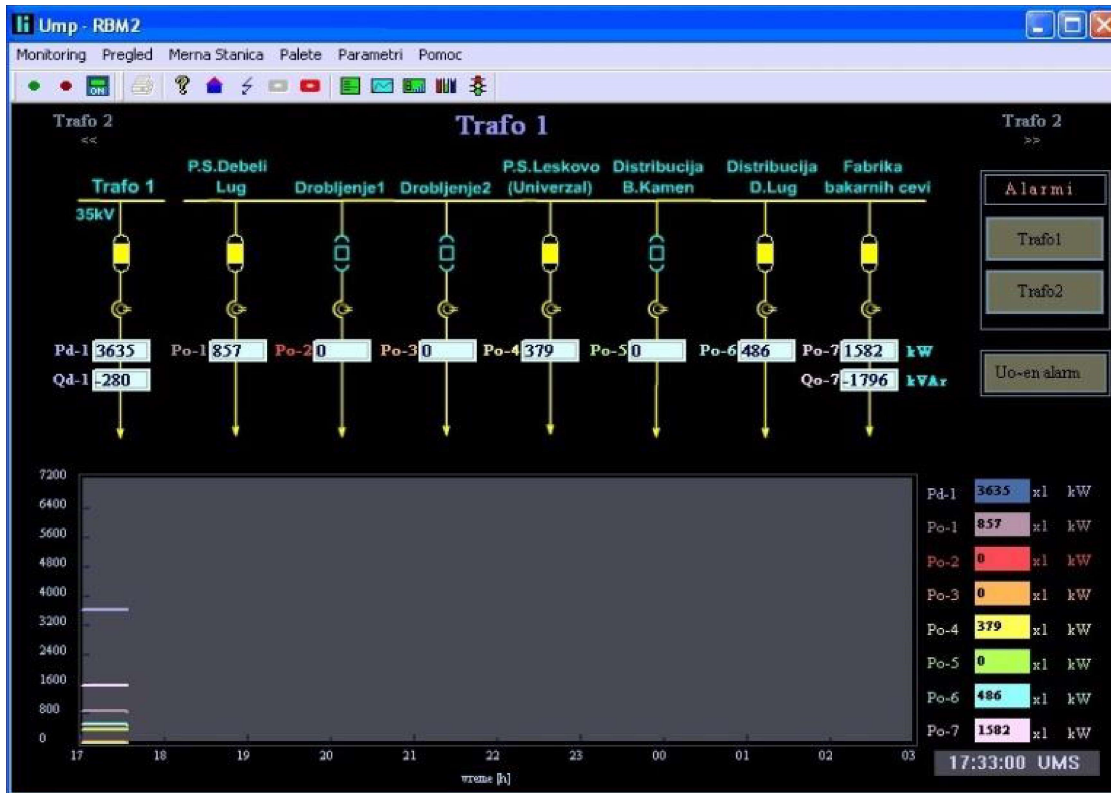

Figure 6. PCP application screenshot

Furthermore, in order to present data about actual electricity consumption PC workstation is used to host web server. It works under the Linux OS with the SQLite database and the Apache web server installed. A Python script that runs every 3 minutes (another time can be set as needed) was used for the data collecting from the Arduino DCS nodes and to records them into the SQLite database.

Python script also generates files with the data needed for the graphical presentations on the web page. Web pages are created by using PHP and JavaScript. Arduino DCS nodes also work as web servers wait for HTTP requests from the host and respond to them by sending measured values from the transducers connected to them.

#### 4. An Example of the Realization of a Lowcost DCS

As an example of the implemented low-cost DCS system, on/off control principle of a three-phase low voltage electric motor by measuring the current in one phase will be shown. This electric motor is part of the ventilation system of the factory. The ventilation system of the factory hall consists of several similar electric motors. Those are consumers who can be stopped, if necessary, for a few minutes in order to avoid the peak power, or exceeding the allowed value of the electricity consumption of the factory. The DCS node is added into the existing overload protection system of this electric motor, as shown in Fig 7. This enables the measurement of current in the single phase of electric motor, or indirectly, assuming a symmetric load at all phases, provide information about actual electric power of this consumer. This information is forwarded via wireless network to a DCS control level (PC workstation). Based on actual electricity consumption of the factory, and other elements contained in the control algorithm, DCS decides whether to turn off the electric motor or not.

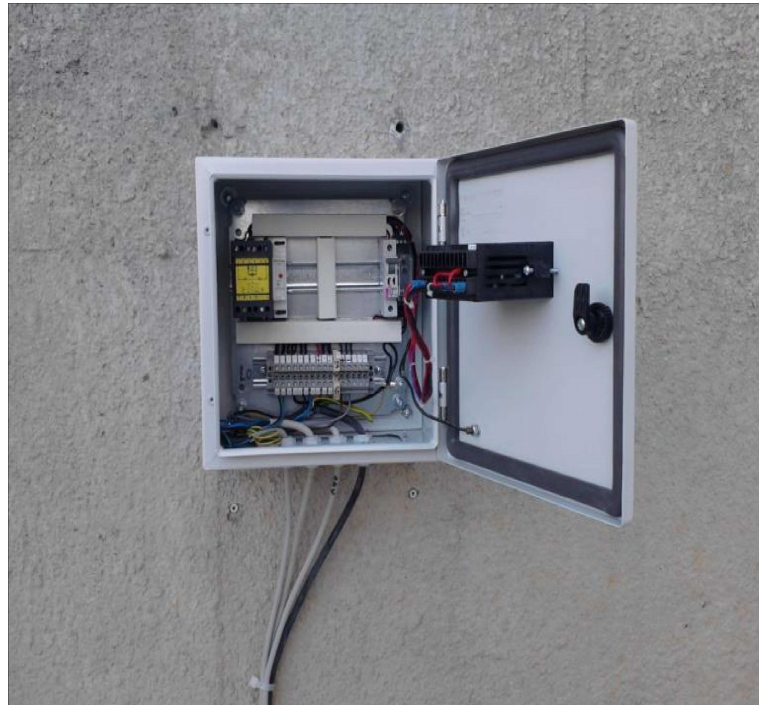

Figure 7. The cabinet with elements of the electric motor overloads protection system

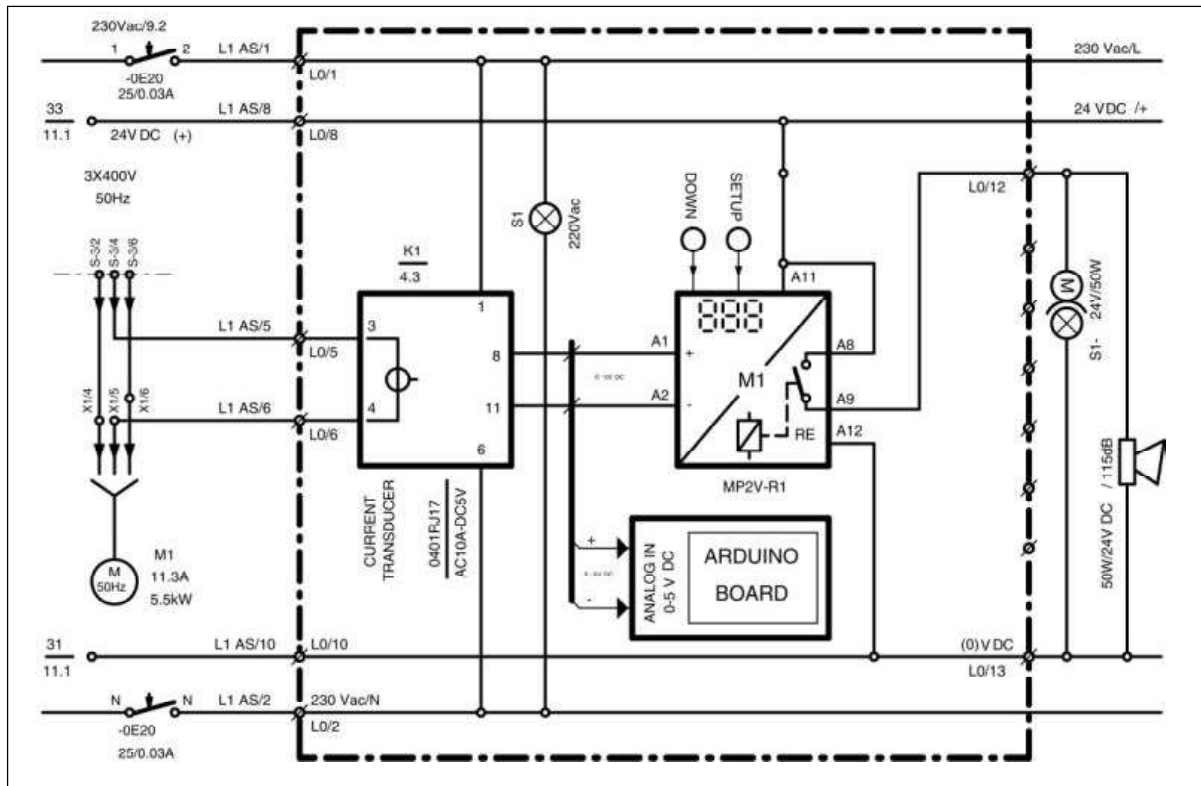

Figure 8. Electric scheme of the electric motor overload protection system with the addition of DCS node

## 5. Conclusion

Development of production technology of microcontrollers and measuring devices leads to the development of low-cost devices that are commercially available. The aim of this paper was to present new low-cost DCS system elements for monitoring and control of the electricity consumption. Unlike the existing DCS, which are based on the consumption control at the transformer stations level, this paper presents the concept of a low-cost DCS, which can be applied to almost all consumers.

In this way, the possibility of optimizing the electricity costs is increased, as is shown in the example of the on/off control of the electric motor. In the upcoming period, we will work on the implementation of the proposed DCS concept, in order to confirm its efficiency in practice in comparison with the existing DCS.

## Acknowledgement

This work was supported by the Ministry of Education, Science and Technological Development of the Republic of Serbia, project no. TR33037: "Development and Application of the Distributed System for Monitoring and Control of Electrical Energy Consumption for Large Consumers."

## References

- [1] Milivojevic, D., Tasic, V., Pavlov, M. & Despotovic, V. (2007) Synthesis of DCS in copper metallurgy. ICEST 2007 [Conference proceedings], Bk. 2, pp. 629–631, Ohrid, FYR Macedonia.
- [2] Tasic, V., Milivojevic, D.R., Pavlov, M. & Despotovic, V. (2010) Reducing the costs of electricity in the copper mining and smelting complex RTB Bor (Serbia) by using of the distributed control system. MIPRO 2010 [Conference proceedings]. Opatija, Croatia, pp. 664–667.
- [3] Tasic, V., Milivojevic, D., Pavlov, M., Despotovic, V. & Brodic, D. (25/5/2012) Microcontroller based systems for peak load reduction. Proceedings of the 35th International Convention, MIPRO 2012, Vol. 21, pp. 919–923, Opatija, Croatia.
- [4] Tasic, V., Milivojevic, D., Despotovic, V., Brodic, D., Pavlov, M. & Stojkovic, I. (2013) Communications in Realized Industrial networks. ICEST 2013 [Conference proceedings], pp. 619–622, Ohrid, FYR Macedonia.
- [5] Tasic, V., Despotovic, V., Brodic, D., Pavlov, M. & Milivojevic, D. (2013) Twenty years of monitoring and control of electricity consumption in RTB Bor, Serbia. MIPRO 2013 [Conference proceedings]. Opatija, Croatia, pp. 1134–1138.
- [6] <https://store.arduino.cc/usa/arduino-mega-2560-rev3>.
- [7] <https://www.arduino.cc/en/Main/Software>.
- [8] Milivojevic, D.R., Despotovic, V., Tasic, V. & Pavlov, M. (2010) Process control program as an element of distributed control system. *Information Technology and Control*, 39, 152–158.
- [9] Stroustrup, B. (2000). *The C++ Programming Language*, 3rd edn. Addison-Wesley Publishing, Co.: Reading, USA.