

# High Bandwidth and Optical Fiber Wireless Network Mobility

Suzana Miladic  
Faculty of Traffic and Transport Engineering  
Doboj at University of East Sarajevo  
[miladics@hotmail.com](mailto:miladics@hotmail.com)



**ABSTRACT:** *In the Fiber-Wireless, the process of combining high bandwidth of optical fiber and wireless network mobility helps to form the hybrid concept. This process is required to implement the broadband fixed and mobile wireless access of the practical concept. In this work we made a survey of integration of optical and wireless networks which help to move to the evolution of fiber wireless access networks and the co-application of these two technologies. We have used the Radio-over-Fiber network approach for the Fiber wireless integration technologies.*

**Keywords:** Optical-wireless Integration, FiWi, RoF

**Received:** 4 May 2022, Revised 17 August 2022, Accepted 30 August 2022

**DOI:** 10.6025/jitr/2022/13/4/99-105

**Copyright:** with authors

## 1. Introduction

To meet the demands of high-capacity and broadband wireless access for future services and applications such as High Definition IPTV (HD IPTV), Video-On-Demand (VoD) and Online Interactive Gaming, the next-generation access networks are driving the needs for the convergence of wired and wireless services. Hybrid fiber-wireless networks for fixed wireless access operating in the sub-millimeter-wave and millimeter-wave (mm-wave) frequency regions are being actively pursued to provide untethered connectivity for ultrahigh bandwidth communications [1]. Therefore, authors of that paper focused on the sub-system and interface designs for WDM-based mm-wave fiber-wireless networks.

Newer standards such as WiMAX and LTE extend the capabilities of existing (WiFi, UMTS) but they are also based on using a lower microwave range which will further increase the occupancy of microwave part of the RF (Radio Frequency) spectrum. The particular area of interest is the unlicensed 60 GHz frequency band, which has 5-mm wavelengths but it is not without challenges, either, which is mentioned at [2]. The advantage of bimodal FiWi systems is that they can enjoy the strength of both optical and wireless technologies.

In recent years significant researches were made focused on the implementation of these systems. Therefore, fixed mobile convergence architectures for broadband access are proposed at [3]. Various challenges and opportunities of FiWi networks are discussed in [4]. This paper deals only with RoF architectures, an approach that is different compared to the R&F (Radio-and-Fiber) network integration mainly because of its use in the indoor environment and outdoor zones for the needs of communication systems.

The paper is organized as follows. Section 2 presents an overview of the structure and the main elements of FiWi networks under the RoF concept. Optical and wireless technologies and their latest developments are presented in section 3. Section 4 introduces advantages of the integration of these two technologies and often combined optical and wireless technologies in RoF approach while section 5 concludes the paper.

## 2. Radio-over-fiber Concept

Radio-over-Fiber is a communication technology for broadband access network where radio signals sent by equipment to Base Stations (BS) modulate a light, transmitting optical data. RF signals that modulate an optical carrier in a Central Station (CS) are being propagated over an analog fiber link to Remote Antenna Units (RAUs) and are then transmitted to clients through the air [5].

RF signal processing, which includes modulation, frequency conversion and multiplexing in conventional wireless communication systems is done on the side of each base station. In RoF systems network complexity is moved to a central base station where all demultiplexing and signal processing are done. Using this architecture each RAU contains a fewer components what reduces the implementation costs. Each base station is adapted to communicate over a radio link with at least one user's mobile station located within the radio range of said base station. Basic architecture of RoF technology is shown at Fig.1 which can be used to distribute the GSM signal at 900 MHz [6]. The RF signal modulate the laser diode in the central site (headend). Modulated optical signal is then transported over the fiber to the BS where transmitted RF signal is recovered by detection in the photodetector. The signal is then amplified and radiated by the antenna. The uplink signal from the mobile units is transported from the RAU to the headend in the same way.

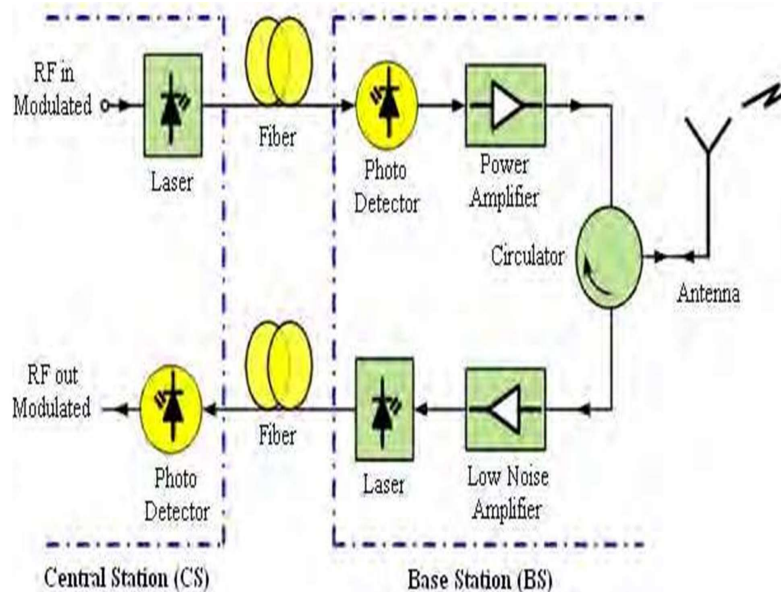

Figure 1. Basic RoF architecture

Applying this concept of FiWi systems the complexity of the equipment at the base stations is reduced because they only perform optoelectronic conversion and signal amplification before the signal is brought to the transmitting antenna. This is opposed to the traditional way where each protocol type requires separate equipment at the location of the antenna.

Depending on the frequency range of the radio signal is transported, RoF transmission systems are usually classified into two main categories: RF-over-Fiber and IF-over-Fiber.

In RF-over-Fiber architecture (RFoF), a data-carrying RF signal with a high frequency (usually greater than 10 GHz) is imposed on a lightwave signal before being transported over the optical link. Therefore, wireless signals are optically distributed to base stations directly at high frequencies and converted from the optical to electrical (O/E) domain at the base stations before being amplified and radiated by an antenna. As a result, no frequency up/down conversion is required at the various base stations, thereby resulting in simple and rather cost-effective implementation is enabled at the base stations.

In IF-over-Fiber architecture (IFoF), an IF (Intermediate Frequency) radio signal with a lower frequency (less than 10 GHz) is used for modulating light before being transported over the optical link. Therefore, before radiation through the air, the signal must be up-converted to RF at the base station. The lowest complexity is achieved by applying the RFoF technique but it requires the solution of other challenges such as chromatic dispersion, spectral efficiency, modulation of the optical carrier, what can significantly affect the overall system performance.

An important application of RoF systems is their use for inbuilding (indoor) distribution of wireless signals of both mobile and data communication systems and its use to provide wireless coverage in the area where wireless backhaul link is not possible. These zones can be areas inside a structure such as a tunnel, areas behind buildings, mountainous places etc. In China, for example, systems are being widely deployed in industrial zones, harbors, hospitals and supermarkets [6]. Plans are in place to expand into rural zones along rail lines, and in new residential and commercial construction spaces. It is believed China will be the leading user of the technology and this will bring down the cost of equipment.

Vehicle Communication and control is also a potential application of RoF technology. Frequencies between 63-64 GHz have already been allocated for this service within Europe. The objective is to provide continuous mobile communication coverage on major roads for the purpose of Intelligent Transport Systems (ITS) such as Road-to-Vehicle Communication (RVC) and Inter-Vehicle Communication (IVC). In the USA RoF systems are deployed in places like stadiums, shopping malls and inside buildings, but their important application is in the satellite communications and beam handling/processing. It involves the remoting of antennas to suitable locations at satellite earth stations.

### 3. Optical and Wireless Technologies and Their Developments

#### 3.1. Optical technologies and standards

The purity of today’s glass fiber, combined with improved system electronics, enables fiber to transmit digitized light signals hundreds of kilometers without amplification. Fiber access systems are also referred to as fiber-to-the-x (FTTx) system, where “x” can be “home,” “building,” “curb,” “premises,” etc., depending on how deep in the field fiber is deployed or how close it is to the user. FTTx is considered as an ideal solution for access networks because of the inherent advantages of optical fiber in terms of huge capacity, small size and weight, and its immunity to electromagnetic interference and crosstalk [7]. For safety reasons fiber should be installed underground and therefore its deployment involves costs so such systems probably will be limited to core and backbone networks. However these systems are well suited to support integrated high bandwidth digital services, and can alleviate bandwidth bottlenecks.

Passive Optical Network (PON) became a solution for "last mile" access, since the "last mile" is the most expensive part of the

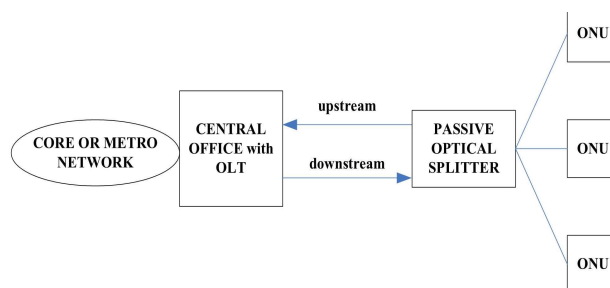

Figure 2. PON access networks

network because there are far more end users than backbone nodes. The optical elements used in such networks are only passive components, such as fibers, splitters/couplers and connectors. A PON is formed by and Optical Line Terminal (OLT), located at the CO (Central Office), and a set of Optical Network Units (ONUs) located at or in the neighbourhood of subscribers' premises. Downstream traffic is broadcast by the OLT to all ONUs and Time Division Multiplexing (TDM) is used for sending data. Upstream traffic uses Time Division Multiple Access (TDMA), under control of the OLT located at the CO, which assigns time slots to each ONU for synchronized transmission of its data bursts (Figure 2).

Today, the development of PON is based on two main standards: ITU-T G.984 Gigabit PON (GPON) and IEEE 802.3ah Ethernet PON (EPON). GPON carries different data types including voice, Ethernet, ATM, leased lines and wireless extension by using a convergence protocol layer designated GFP (Generic Framing Procedure) [8] while EPON carries Ethernet frames with symmetric rates equal to 1.25 Gbit/s. Some characteristics of the GPON standard are: physical reach of at least 20 km, with support for logical reach up to 60 km, support of several data rate options, using the same protocol, including a symmetrical link at 622 Mbit/s or 1.25 Gbit/s, or 2.5 Gbit/s downstream with 1.25 Gbit/s upstream. Future developments of GPON and EPON are related to capacity increase through combinations of TDM with WDM (Wavelength Division Multiplexing), then increase of data rates, with faster lasers and more sensitive burst-mode receivers.

### 3.2. Wireless Technologies and Standards

The IEEE 802.11x (x = a, b, g) family of standards also known as Wi-Fi is the technology that has dominated the wireless local area networking (WLAN) market worldwide in the last decade. These standards support the WLAN functionality where one Access Point (AP) is able to serve several users in a range of 100 m indoor to 400 m outdoor with rates up to 54 Mbit/s (802.11g) [5].

IEEE 802.16 otherwise known as WiMAX is another type of access technology which uses radio waves for last-mile connectivity. WiMAX seeks to provide high-bit rate mobile services using frequencies between 2–11 GHz and aims to provide Fixed Wireless Access (FWA) at bit-rates in the excess of 100 Mbit/s and at higher frequencies between 10–66 GHz [9]. WiMAX can provide at-home or mobile Internet access across whole cities or countries and its bandwidth and range make it suitable for the following potential applications: providing portable mobile broadband connectivity across cities and countries through a variety of devices, providing a wireless alternative to cable and digital subscriber line (DSL) for "last mile" broadband access and providing data, telecommunications (VoIP) and IPTV services. WiMAX cannot deliver 70 Mbit/s over 50 kilometers. Like all wireless technologies, WiMAX can operate at higher bitrates or over longer distances but not both. Operating at the maximum range of 50 km increases bit error rate and thus results in a much lower bitrate. Conversely, reducing the range (to under 1 km) allows a device to operate at higher bitrates. One way to increase capacity of wireless communication systems is to deploy smaller cells (micro- and pico-cells) or to increase the carrier frequencies. But, at the same time, smaller cell sizes mean that large numbers of BSs in order to achieve the wide coverage required of ubiquitous communication systems.

IEEE works on the new 802.16m amendment which adds many enhancements while being backward compatible with previous WiMAX standards. It will support various MIMO schemes, QoS, Multi-hop Relaying, which allows for range extension and avoidance of coverage holes and Multi-Carrier Aggregation where one or more clients may use more than one channels, depending on channel availability, increasing in this way the data rates up to 100 Mbit/s for mobile clients and 1 Gbit/s for fixed clients [5].

## 4. Advantages and Benefits of the RoF Technology

Integration of optical and wireless technologies under the Radio-over-Fiber concept has some advantages compared with conventional optical and wireless signal distribution, where it is obviously that combining these two technologies we get the new one with better performances, in order to achieve efficiency of the telecommunications services market.

These performances are related to: ability to transport long distance with high fidelity, modulation format transparent, centralized control of electronic circuitry, compact and reliable. More detailed form of the RoF system and its central base station is shown at Figure 3. The possibility of integration of different wireless systems, including Wi-Fi and WiMAX with PON technology in the future Fi-Wi systems is proposed at [7] while combination of different WLAN and Wireless Mesh Networks (WMN) with optical access architectures based on PON technology (EPON) are demonstrated at [2,10].

### 4.1. Low Attenuation Loss and Huge bandwidth of Optical Fiber

Attenuation is the progressive loss of signal strength as the signal propagates along the cable. The effective resistance of a

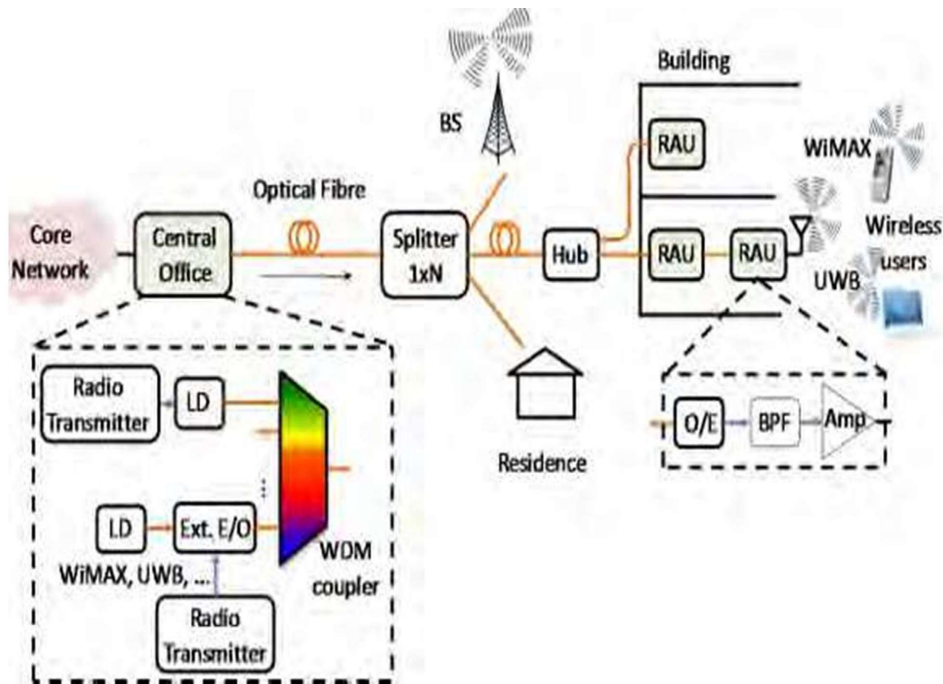

Figure 3. The complex form of the RoF technology and its central base station

cable increases with frequency because of the so-called skin effect. The skin effect is strongly dependent on frequency, rising rapidly with increased frequency. Electrical distribution of high frequency microwave signals either in free space or through transmission lines is problematic and costly [6].

Signals transmitted on optical fiber attenuate much less than through other media, especially when compared to wireless medium. By using optical fiber, the signal will travel further, reducing the need of repeaters. Optical fiber communications bounces light around inside a fiber and the result is no crosstalk and less attenuation because optical fibers don't suffer from the skin effect. You can back hundreds of fibers together and it would not make a difference. In transmission lines and in free space higher frequency means higher impedance and increasing of absorption and reflection respectively which includes more expensive equipment. The potential solution for this problem is to distribute signals at low intermediate frequencies from the switching centre to the base station. The baseband or IF signals are up-converted to the required microwave or mm-wave frequency at each base station, amplified and then radiated. There are three main transmission windows, which offer low attenuation, namely the 850 nm, 1310 nm, and 1550 nm wavelengths. Attenuation of the RF signal transmitted optically are below 0.2 dB/km and 0.5 dB/km in the 1550 nm and the 1300 nm windows, respectively what is much lower than those in coaxial cable.

Because of operating at higher frequencies, optical fibers offer enormous bandwidth. The high optical bandwidth enables faster transmission and high speed signal processing which can be implemented in the optical domain. Since the microwave functions such as filtering, mixing, up- and downconversion are implemented in the optical domain it is possible to use cheaper low bandwidth optical components such as laser diodes and modulators, and still be able to handle high bandwidth signals. The capacity of the fiber optic networks in mm-wave fiber-radio systems can be increased by applying WDM technology. In analogue optical systems including RoF technology, Sub-Carrier Multiplexing (SCM) is used where a large number of mm-wave channels, each carried by a separate wavelength, are transmitted to/from the BSs via the CO through a single fiber.

#### 4.2. Immunity to Radio Frequency Interference

This advantage is consequence of the fact that fiber optic carries signals as light waves instead of electrical impulses and therefore it is immune to EMI (Electromagnetic Interference) and does not create its own EMI. Also, it is immune to RFI, or Radio Frequency Interference and emit no radiation. Since fiber optic systems do not emit RF signals, they are difficult to tap into without being detected what provides privacy and security.

### 4.3. Centralized Control and Reduced Power Consumption

To make the base station compact and cost-effective it has been proposed that RoF technique be used to transfer the complicated RF modem and signal processing functions from the base station to a centralized control station where all signal processing are done. The typical distances between the CO and the BSs are 5-50 km, where each of the BS serves a microcell or picocell covering the distances of few ten's to few 100's metres. Centralised network arrangement allows easy installation and maintenance and simplifies the BSs to having transmitter and receiver with additional optoelectronic & electrooptic (O/E) interface to detect and transmit optical mm-wave signals. It also allows securing the sensitive and delicate equipment in a central location, in addition to enabling them to be shared between a larger numbers of customers.

As the complexity of each base station is reduced and their large numbers are required the costs of system installation and maintenance are much smaller. The much lower power level eliminates the needs for expensive frequency multiplexes and high power amplifiers currently employed at base stations so the consequence of having simple RAUs with reduced equipment is reduced power consumption. Reducing the cell size the radiated power at the antenna is reduced to.

### 4.4. Modulation Format Transparency and Compactness

The RoF distribution system can be made signal-format transparent. For instance the Intensity Modulation and Direct Detection (IM-DD) technique can be made to operate as a linear system and therefore as a transparent system [6]. Using low dispersion fiber in combination with pre-modulated RF subcarriers the same RoF network can be used to distribute multi-operator and multi-service traffic, resulting in huge economic saving. Since RF functions are performed at a centralized station, there is the possibility of dynamic capacity allocation to individual BS. For example more capacity can be allocated to an area in accordance with the needs and then reallocated to other areas when off-peak because allocating constant capacity would be a waste of resources. This can be done by allocating optical wavelengths through WDM as need arises.

## 5. Conclusions

This paper has reviewed the current advantages of using Radio-over-Fiber technology. Despite of these advantages it is also important to mention it's limitations which are related to noise and distortion since RoF involves analogue modulation, and detection of light. So, fundamentally, it is an analogue transmission system. In analogue optical fibre links the noise sources include the laser's Relative Intensity Noise (RIN), the laser's phase noise, the photodiode's shot noise, the amplifier's thermal noise, and the fibre's dispersion so Bit Error Rate (BER) may be affected by transmission channel noise, interference and distortion. The BER may be improved by choosing strong signal strength or choosing a slow and robust modulation scheme. Also, because all the processing in RoF is moved towards the CS a possible failure inside the CS will endanger overall service availability.

As a new research topic, FiWi broadband access network is a promising "last mile" access technology, because it integrates wireless and optical access technologies in terms of their respective merits and it should be more explored before commercial deployment, so many issues must be considered such as peer-to-peer communication, multicasting, which are also significant and can be the subject of further researches.

## References

- [1] Lim, C., Nirmalathas, A., Bakaul, M., Gamage, P., Ka-Lun Lee, Yizhuo Yang, Novak, D. & Waterhouse, R. (2010) Fiber-Wireless networks and subsystem technologies. *Journal of Lightwave Technology*, 28, 390–405
- [2] Markovic, G. & Radojicic, V. (2011) Hybrid Fiber Wireless next generation networks. In: *PosTel. Proceedings of the vol, Vol. 1. Belgrade*, pp. 268–278, 06-07 December 2011.
- [3] Shen, G. et al. (2005) Fixed mobile convergence architectures for broadband access: Integration of EPON and WiMAX. *IEEE Communications Magazine*, 45, 44–50.
- [4] Ghazisaidi, N. & Maier, M. (2011) *Fiber-Wireless (FiWi) networks: Challenges and Opportunities. IEEE Network*, 25, 36–42
- [5] Tsagklas, T. & Pavlidou, F.N. A Survey on Radio-and-Fiber FiWi Network Architectures, *Journal of Selected Areas in Telecommunications (JSAT), march edition* (2011).

- [6] Ng'oma, A. (2005). *Radio-Over-Fiber Technology for Broadband Wireless Communication Systems*. Faculty of Electrical Engineering of the Eindhoven University of Technology, Ph.D [Thesis]. Netherlands, ISBN: 90-386-1723-2.
- [7] Chowdhury, P., Mukherjee, B., Sarkar, S., Kramer, G. & Dixit, S. (2009) *Hybrid Wireless-Optical Broadband Access Network WOBAN: Prototype development and research challenges*. *IEEE Network*, 23, 41–48
- [8] da Silva, H.J.A. (09/03/2005). “*Optical Access Networks*”, available at web. [www.co.it.pt](http://www.co.it.pt).
- [9] Aditya, G. & Er, R.K. (2009) Sethi. Integrated Optical Wireless Network for Next Generation Wireless Systems, *Signal Processing: An International Journal (SPIJ)*, 3, 1–13.
- [10] Wang, X. & Lim, A.O. (2008) IEEE 802.11s Wireless Mesh Networks: Framework and Challenges. *Ad Hoc Networks*, 6, 970–984