

Total Bond Graphs for Three-Dimensional Crane Systems

Dragan Antic¹, Dragana Trajkovic², Saša Nikolic¹, Staniša Peric¹ and Marko Milojkovic¹

¹Faculty of Electronic Engineering at University of Niš, A.

Medvedeva, 18000 Niš, Rep. of Serbia

{[dragan.antic](mailto:dragan.antic@elfak.ni.ac.rs), [sasa.s.nikolic](mailto:sasa.s.nikolic@elfak.ni.ac.rs), [stanisa.peric](mailto:stanisa.peric@elfak.ni.ac.rs), [marko.miljkovic](mailto:marko.miljkovic@elfak.ni.ac.rs)}@elfak.ni.ac.rs

²Faculty of Mechanical Engineering at University of Niš

A. Medvedeva, 18000 Niš, Rep. of Serbia

dragana.trajkovic@masfak.ni.ac.rs



ABSTRACT: For an industrial three-dimensional crane system, we have developed a model using the Bond Graph method with simulation. We have initially provided the description of the proposed model, where the total bond graph model is given. For concrete values of measured, we have conducted many simulation exercises. We have obtained the simulation results which are compared and verified. We found the system dynamics enough and the bond graph system is confirmed.

Keywords: Bond graph, 3D crane, Dymola, Modelling and simulation

Received: 13 September 2022, Revised 28 November 2022, Accepted 9 December 2022

DOI: 10.6025/jmpt/2023/14/1/1-7

Copyright: with Authors

1. Introduction

The concept of bond graphs was first developed by Paynter [1]. The main idea was further developed by Karnopp and Rosenberg [2, 3]. The fundamental advantage of bond graphs is in central physics concept-energy (bond graph consists of components which exchange energy using connections; these connectors represent bonds). The effort (voltage, force, pressure, etc.) and the flow (current, velocity, volume, flow rate, etc.) are generalization of similar phenomena in physics. The factors which characterize the effort and flow have different interpretations in different physical domains (mechanical, electrical, hydraulic, thermal, chemical systems).

Obtained model can be successfully tested in software package Dymola which is adjusted for simulation purposes.

Dymola is a commercial modelling and simulation environment based on the open Modelica modelling language (an object-oriented, declarative, multi-domain modelling language for component-oriented modelling of complex systems). The BondLib library, firstly presented by Cellier in 2003, is designed as a graphical library for modelling physical systems using the bond graph metaphor. This library contains the basic elements for analog electronic circuits, translational and rotational mechanical systems, hydraulic and thermal systems.

It is already proven in many papers that bond graph technique can be successfully used as a modelling tool for various types of process [4-10]. In [11, 12] we used bond graph method for modelling of submersible pumps in water industry. The obtained model is used as an object for the control design based on orthogonal polynomials.

In this paper we present the process of modelling and simulation of three-dimensional laboratory model of industrial crane. In addition, the simulation of obtained model is performed using Dymola and simulation results are presented and discussed. In order to verify the effectiveness of obtained bond graph model, the simulation results are compared with already existing one and it is proved that this model fully describe the 3D industrial crane system dynamics. In future work, obtained model can be used as a plant for design of some control algorithms based on advance control method.

2. 3D Crane System Description

Three-dimensional laboratory model of industrial crane (see Fig. 1), made by Inteco [13], is a highly non-linear electromechanical system having a complex dynamic behaviour and creating challenging control problems. It consists of a payload hanging on a pendulum-like lift-line wound by a motor mounted on a cart. The payload is lifted and lowered in the z direction. Both the rail and the cart are capable of horizontal motion in the x direction. The cart is capable of horizontal motion along the rail in the y direction. Therefore the payload attached to the end of the lift-line can move freely in three dimensions. The 3D crane is driven by three DC motors.



Figure 1. The 3D crane system manufactured by Inteco

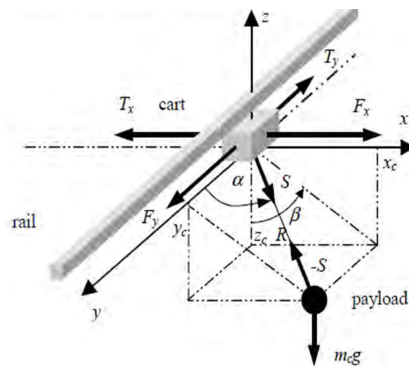

Figure 2. Free body diagram of the 3D crane system

There are five identical encoders measuring five state variables: x_w represents the distance of the rail with the cart from the centre of the construction frame; y_w is the distance of the cart from the centre of the rail; R denotes the length of the lift-line; α represents the angle between the y axis and the lifeline; β is the angle between the negative direction on the z axis and the projection of the lift-line onto the xz plane. The schematic representation of the 3D crane system is shown in Figure 2.

The relationships that describe a given system are [14]:

$$\mu_1 = \frac{m_c}{m_w}, \mu_2 = \frac{m_c}{m_w + m_s}, \quad (1)$$

$$u_1 = \frac{F_x}{m_w}, u_2 = \frac{F_y}{m_w + m_s}, u_3 = \frac{F_R}{m_c}, \quad (2)$$

$$T_1 = \frac{T_x}{m_w}, T_2 = \frac{T_y}{m_w + m_s}, T_3 = \frac{T_R}{m_c}, \quad (3)$$

$$N_1 = u_1 - T_1, N_2 = u_2 - T_2, N_3 = u_3 - T_3, \quad (4)$$

where m_c, m_w, m_s - mass of the payload, cart and moving rail, respectively, x_c, y_c, z_c - coordinates of the payload, S - reaction force in the lift-line acting on the cart, F_x - force driving the rail with cart, F_y - force driving the cart along the rail, F_R - force controlling the length of the lift-line and T_x, T_y , - friction forces.

The load position is described by the following equations:

$$x_c = x_w + R \cos \alpha, \quad (5)$$

$$y_c = y_w + R \sin \alpha \sin \beta, \quad (6)$$

$$z_c = -R \sin \alpha \cos \beta, \quad (7)$$

$$R^2 = (y_c - y_w)^2 + z_c^2 + (x_c - x_w)^2. \quad (8)$$

Crane dynamics is described by:

$$m_c \ddot{x}_c = -S_x, m_c \ddot{y}_c = -S_y, m_c \ddot{z}_c = -S_z - m_c g. \quad (9)$$

where S_x, S_y, S_z are components of the force i.e.:

$$S_x = S \cos \alpha, S_y = S \sin \alpha \sin \beta, S_z = -S \sin \alpha \cos \beta. \quad (10)$$

The first two DC motors control the position of the cart and the last one controls the length of the lift-line. If the flag is set to 1 and the encoder detects range over sizing, the corresponding DC motor is switched off. If the flag is set to 0 the motion continues in spite of the range limit exceeded in the encoder register.

3. Bond Graph Model of Three-dimensional Industrial Crane

The basics elements, used in bond graph model of 3D crane system, are: the resistor R (dissipative element), the capacitor C , the inductor I (energy storage element), the modulated transformer MTF , the gyrator GY (conservative element), the effort and flow sources (energy source elements). There are also junction structure elements: 0-junction and 1-junction. The 0-junction is a flow balance junction or a common junction. It has a single effort on all its bonds and the algebraic sum flows is null. The 1-junction is an effort balance junction or a common flow junction. It has a single flow on all its bonds and the algebraic sum of effort is null. The effort source S_e in z axis enters effort, i.e. force of gravity mg , while flow sources S_f from DC motors in x, y, z axis enters flowsvelocity as a starting information in the process. DC motors are included individually. Junction with the identical flow $1a$ presents the port with the same velocity and sum of forces gravity, inertial force from payload and velocity from DC motor. The first derivative of positions z_c, y_c, x_c represents the corresponding velocities $\dot{z}_c, \dot{y}_c, \dot{x}_c$ of the payload. Junction $1d$ is a sum of inertia of the cart and friction forces $R: T_x$. Junction $0a$ is defined as a sum of velocities in functions of variables-string radius R \dot{R} and angular velocity $\dot{\alpha}$, where the output force from $0a$ is input in junction $1d$ while output bond is inertia of payload. Junction $1f, 1g$ and $1h$ defines the velocities $\dot{\alpha}, \dot{\beta}$ and \dot{R} . Junction $0a, 0b, 0c$ and $1a, 1b, 1c$ are defined with the following equations:

$$0a : \dot{x}_c = \dot{x}_w + \dot{R} \cos \alpha - R \dot{\alpha} \sin \alpha , \quad (11)$$

$$0b : \dot{y}_c = \dot{y}_w + \dot{R} \sin \alpha \sin \beta + R \dot{\alpha} \cos \alpha \sin \beta + R \dot{\beta} \sin \alpha \cos \beta , \quad (12)$$

$$0c : \dot{z}_c = -\dot{R} \sin \alpha \cos \beta - R \dot{\alpha} \cos \alpha \cos \beta + R \dot{\beta} \sin \alpha \sin \beta , \quad (13)$$

$$1a : m_c \ddot{x}_c = -m_c g - R \sin \alpha \cos \beta + S f_{DCmotor} , \quad (14)$$

$$1d : m_w \ddot{x}_w = S f_{DCmotor} - T_x + S \cos \alpha , \quad (15)$$

$$1c : (m_w + m_s) \ddot{x}_w = S f_{DCmotor} - T_y + S \sin \alpha \sin \beta . \quad (16)$$

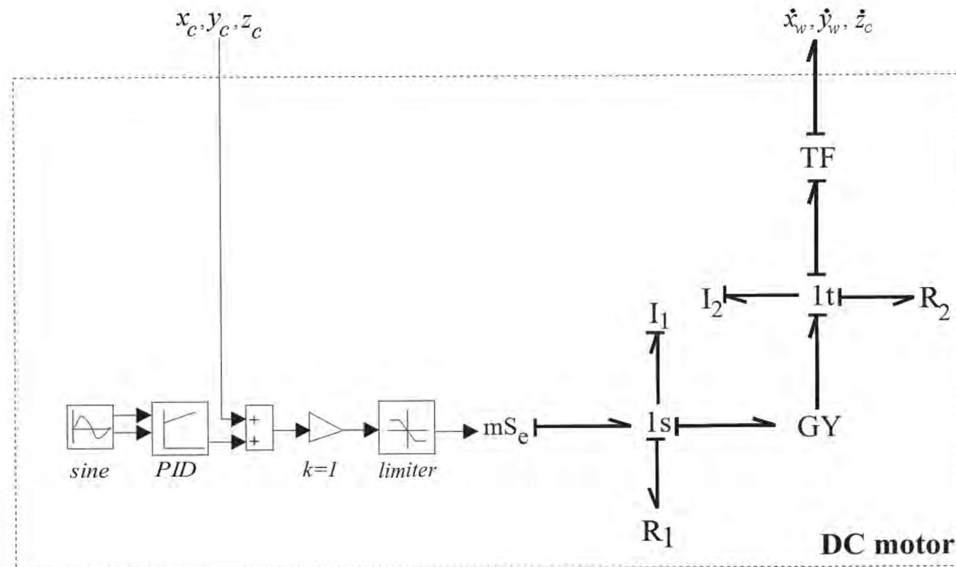

Figure 3. Bond graph model of the DC motor

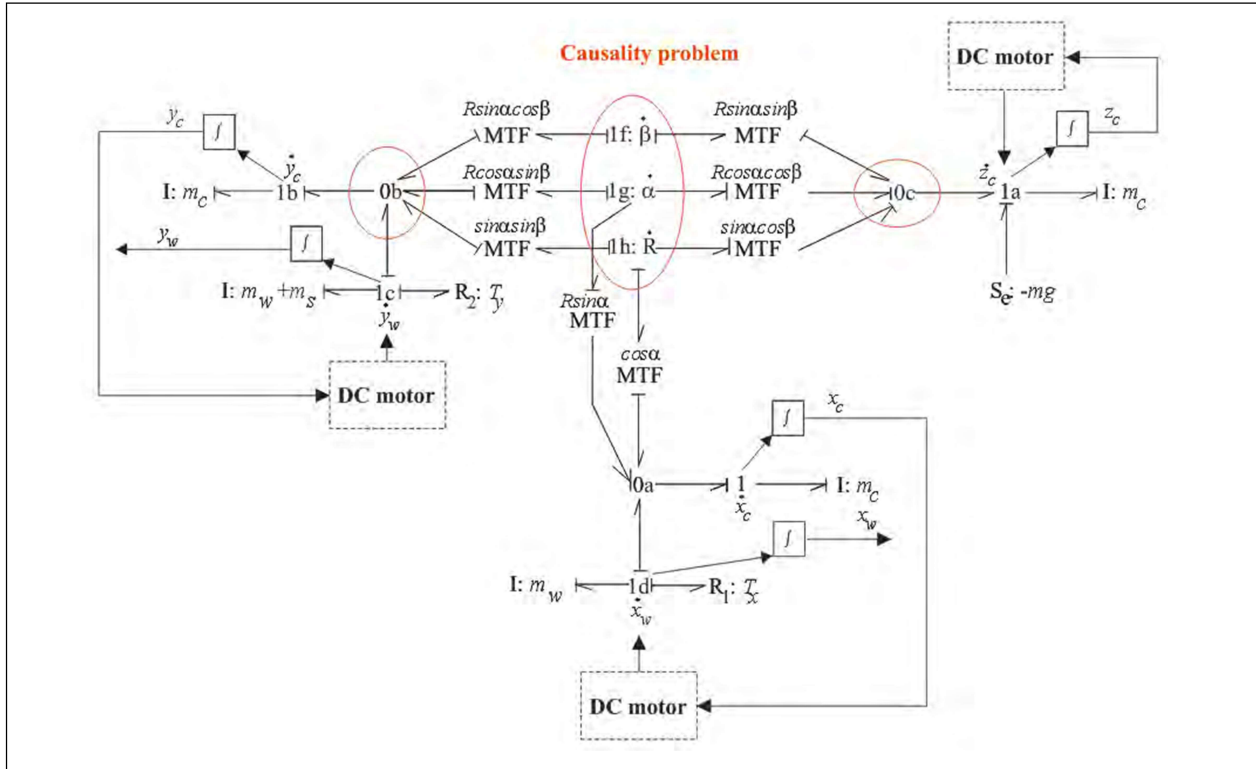

Figure 4. Acausal bond graph model of the 3D crane system

Bond graph model of the DC motor (see Fig. 3) consists of two 1- junctions, two R and two I elements. There exists commonly junction 1s and 1t with the identical flow contains for four bonds. A PIDs controller for the positions, voltages and limiters are connected to motors. The main problem is reflected in causality and it is avoided using acausal bond graph. To derive the total acausal bond graph, there is need to create two kinds of connector class: e-connector, f-connector to establish acausal bond, where: the Se-element stands for the voltage and forces source; the seven I-elements represent the moment of inertia derived from the mass and the magnetic energy and the kinetic energies of the rotor and the load from DC motor; the six R-elements enable the friction and the dissipative energy in the electrical circuit; the GY-element depicts the electro-mechanical coupling; the MTF-element is associated to the power conserving rotation into translation velocities. The total acausal bond graph of the 3D crane system is illustrated in Figure 4. It is based on the system equations (5)-(10). Model is described by three unknown coordinates of the two angular velocities.

4. Simulation Results

In order to verify the efficiency of proposed method for modelling of 3D crane system and validity of obtained model, we performed the several simulations in Dymola. The considered parameters of simulation are: $\alpha = 10^\circ$, $\beta = 30^\circ$, $m_c = 0.35\text{kg}$, $m_w = 0.8\text{kg}$, $m_s = 0.5\text{kg}$, $T_x = 0.235\text{Nm}$. The parameters used for the DC motor are: $L = 0.02\text{H}$; $R_1 = 4\Omega$; $R_2 = 2.5\text{Nm/s}$; $J = 0.2\text{kgm}^2$. Simulation time is $t = 0.02\text{s}$. In Fig. 5, position responses for x, y and z-axis are presented. These simulation results are compared with simulation results presented in [13]. It can be noticed that obtained results (dashed lines) are very close to the existing one (solid line), which proves that bond graph model fully determines system dynamics. This is useful for student exercises where they can implement their control algorithm based on different models. Also, in some application the bond graph model is more suitable for controller design than conventional one, obtained in other graphic tool environment.

5. Conclusion

In this paper we presented the bond graph technique applied in modelling of three-dimensional (3D) laboratory crane system.

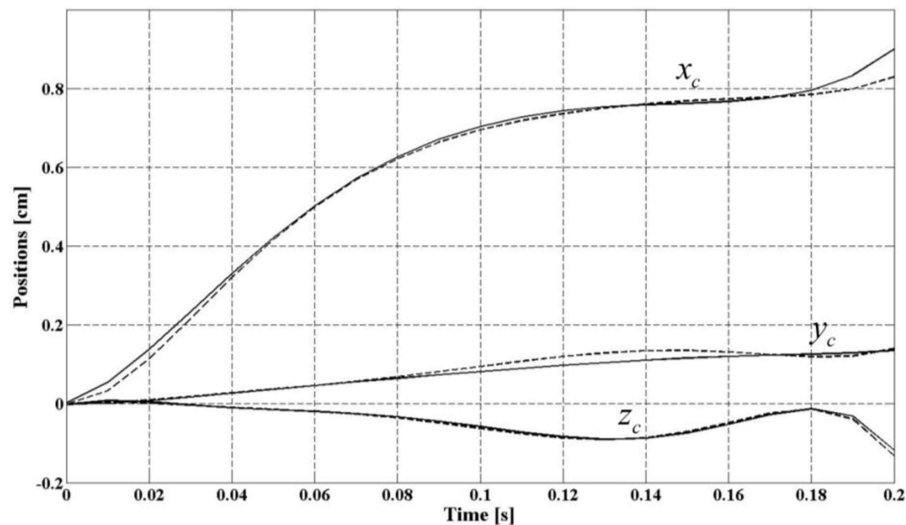

Figure 5. Position responses for x , y , and z -axis

First, the complete mathematical background of considered system is given. After that, the complete process of bond graph modelling is described and corresponding bond graph models are presented. Finally, the bond graph model of 3D crane system is tested through simulations in Dymola and obtained results are compared with already existing one. It is proved that bond graph model fully determined the 3D crane system dynamics. In future work, this model can be used as a plant for controller design.

Acknowledgement

This paper was realized as a part of the projects TR 35005, III 43007 and III 44006 financed by the Ministry of Education, Science and Technological Development of the Republic of Serbia.

References

- [1] Paynter, H.M. (1961). *Analysis and Design of Engineering Systems*. M.I.T. Press: Cambridge, USA.
- [2] Rosenberg, R.C. & Karnopp, D.C. (1983). *Introduction to Physical System Dynamics*. McGraw-Hill Book, Co.: New York, USA.
- [3] Karnopp, D.C., Margolis, D.L. & Rosenberg, R.C. (1990). *System Dynamics: A Unified Approach*. John Wiley & Sons: New York, USA.
- [4] Ould Bouamama, B., Medjaher, K., Bayart, M., Samantaray, A.K. & Conrard, B. (2005) Fault detection and isolation of smart actuators using bond graphs and external models. *Control Engineering Practice*, 13, 159–175 [DOI: [10.1016/j.conengprac.2004.03.003](https://doi.org/10.1016/j.conengprac.2004.03.003)].
- [5] Pacejka, H.B. (1985) Modelling complex vehicle systems using bond graphs. *Journal of the Franklin Institute*, 319, 67–81 [DOI: [10.1016/0016-0032\(85\)90065-1](https://doi.org/10.1016/0016-0032(85)90065-1)].
- [6] Mosterman, P.J., Kapadia, R. & Biswas, G. (1995) Using bond graphs for diagnosis of dynamic physical systems. In: *Proceedings of the 5th International Workshop on Principles of Diagnosis*, pp. 81–85.
- [7] Sueur, C. & Dauphin-Tanguy, G. (1991) Bond-graph approach for structural analysis of MIMO linear systems. *Journal of the*

Franklin Institute, 328, 55–70 [DOI: 10.1016/0016-0032(91)90006-O].

[8] Sosnovsky, E. & Forget, B. (2013) Bond graphs for spatial kinetics analysis of nuclear reactors. *Annals of Nuclear Energy*, 56, 208–226 [DOI: 10.1016/j.anucene.2013.01.012].

[9] Ragavan, S. V., Shanmugavel, M., Shirinzadeh, B. & Ganapathy, V. (2012) Unified modelling framework for UAVs using bond graphs. In: 12th International Conference on Intelligent Systems Design and Applications (ISDA), pp. 21–27 [DOI: 10.1109/ISDA.2012.6416507].

[10] Trajkovic, D., Nikolic, V., Antiæ, D. & Dankoviaæ, B. (2005) Analyzing, modelling and simulation of the cascade connected transporters in tire industry using signal and bond graphs. *Machine Dynamics Problems*, 29, 91–106.

[11] Trajkovic, D., Nikolic, V., Antiæ, D., Nikoliaæ, S. & Periaæ, S. (in press) Application of the hybrid bond graphs and orthogonal rational filters for sag voltage effect reduction. *Electronics and Electrical Engineering*, 19 [DOI: 10.5755/j01.eee.19.6.1746].

[12] Trajkovic, D., Nikolic, V., Nikoliaæ, S., Peric, S. & Milojkoviaæ, M. (2012) Modeling and simulation of pump station using bond graphs International Conference on Systems, *Automatic Control. and Measurements*, SAUM 2012, Vol. XI, pp. 455–458.

[13] Inteco (2008). *Crane System-User's Manual*. Available at www.inteco.com.pl, p. 3D.

[14] Jovanovic, Z., Antic, D., Stajic, Z., Miloševic, M., Nikolic, S. & Peric, S. (2011) Genetic algorithms applied in parameters determination of the 3D crane model. *Facta Universitatis. Series Automatic Control and Robotics*, 10, 19–27.