

Development of a System for Power Supply Monitoring and Autonomous Ignition of Gasoline Ignition Aggregated with Enlisting Functions

Goran Goranov
Technical University of Varna
Bulgaria



Iskren Kandov
Technical University of Varna
Bulgaria

ABSTRACT: *We in this work have studied the presence of electrical power supply and observed the petrol aggregate which is autonomous. The design, framework and functions of the autonomous ignition aggregate system are explicitly described in this work.*

Keywords: Component, Aggregate, Power Supply Monitoring, Autonomous Power

Received: 12 September 2022, Revised 3 December 2022, Accepted 12 December 2022

DOI: 10.6025/jdp/2023/13/1/10-17

Copyright: with authors

1. Introduction

The development of a system for monitoring of the supply pressure is necessary in the cases when the process of the work of a given facility or a machine does not have to be interrupted, because of the voltage's interruptions in the power supply network. These kind of systems are used in the medicine, in the military technics and in some higher levels of computational machines. The uninterruptible power supply (UPS) based systems for emergency power supply can not always provide alternative power supply for a long time [1]. The reasons for that are the type of the batteries and the batteries's capacity (li-ion, ni-mh, etc.).

The usage of the alternative power supply systems based on a petrol or a diesel engine is appropriate in these cases when the work process allows interruption of the power supply for a short time. The interruption time is determined by the type of the aggregate and the needed time for establishing of the direct current (DC). The estimation time can be critical in the cases when medical or computer equipment are supplied [2]. Even more, it is a well known fact that the diesel aggregates, which also provide and higher power supply (over 10 000 W) are more expensive than the petrol aggregates. This makes the diesel aggregates applicable for lower consumptions [3].

In order to avoid the power supply interruptions, even for milliseconds, and also to generate alternative energy, composite power supply systems are used. These systems contain of a set of other systems: a system for managing and monitoring of the supply pressure, a UPS system and a petrol aggregate for generating the electricity.

In the current report a development of a system for monitoring of the supply pressure of the electrical power supply is provided. In the cases of the supply pressure's absence an autonomous ignition of a petrol aggregate is initiated. As a result a constant electrical power is provided. The development meets the requirements of the ProHost LTD company, which is a hosting service provider in the bulgarian market. This investigation is applied in the cases of support of the constant electrical power for the company's server room facilities.

2. The Control System Development

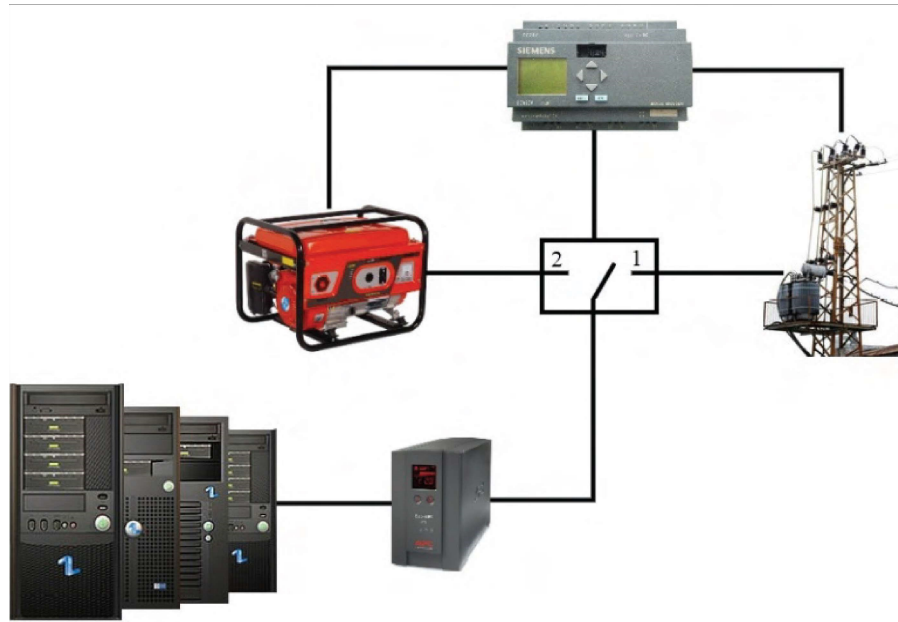

Figure 1. Network of power

The purpose of the control system is to monitor the presence on the electrical power supply and to provide alternative power for indefinite time in the cases when the power supply is not available. On the Fig.1 is shown simplified scheme of an example solution for the case of uninterruptible power supply.

The system can be also used to control and switch the power supply from the network and the electrical power that comes from the petrol aggregate. If electrical power is available, the on-line UPS transfers the electrical power to the server room. If the electrical power from the network is not available, the control system sends signal to the petrol engine to start working. The server room is powered by the UPS's battery, for the time which is needed to the network to establish baseline voltage. The control system switches the power supply from the network to the power that comes from the aggregate. The electrical power that is generated from a petrol aggregate is used to ensure the electrical power to the server's room and also to charge the UPS's battery. In the case when the on-line UPS is used there is no interruption of the power to the server room. This is not the case when the offline UPS (5ms) is used.

On the Figure 2 is shows a block diagram of the developed control system. The control system is based on a programable logic controller (PLC) Siemens LOGO!12/24RC.

This controller possesses the necessary resources for the implementation [4, 5]:

- Sufficient number of physical inputs and outputs;
- Relay outputs - galvanically isolated with maximum current of 10A;
- The controller has two inputs which can be configured as analog inputs;

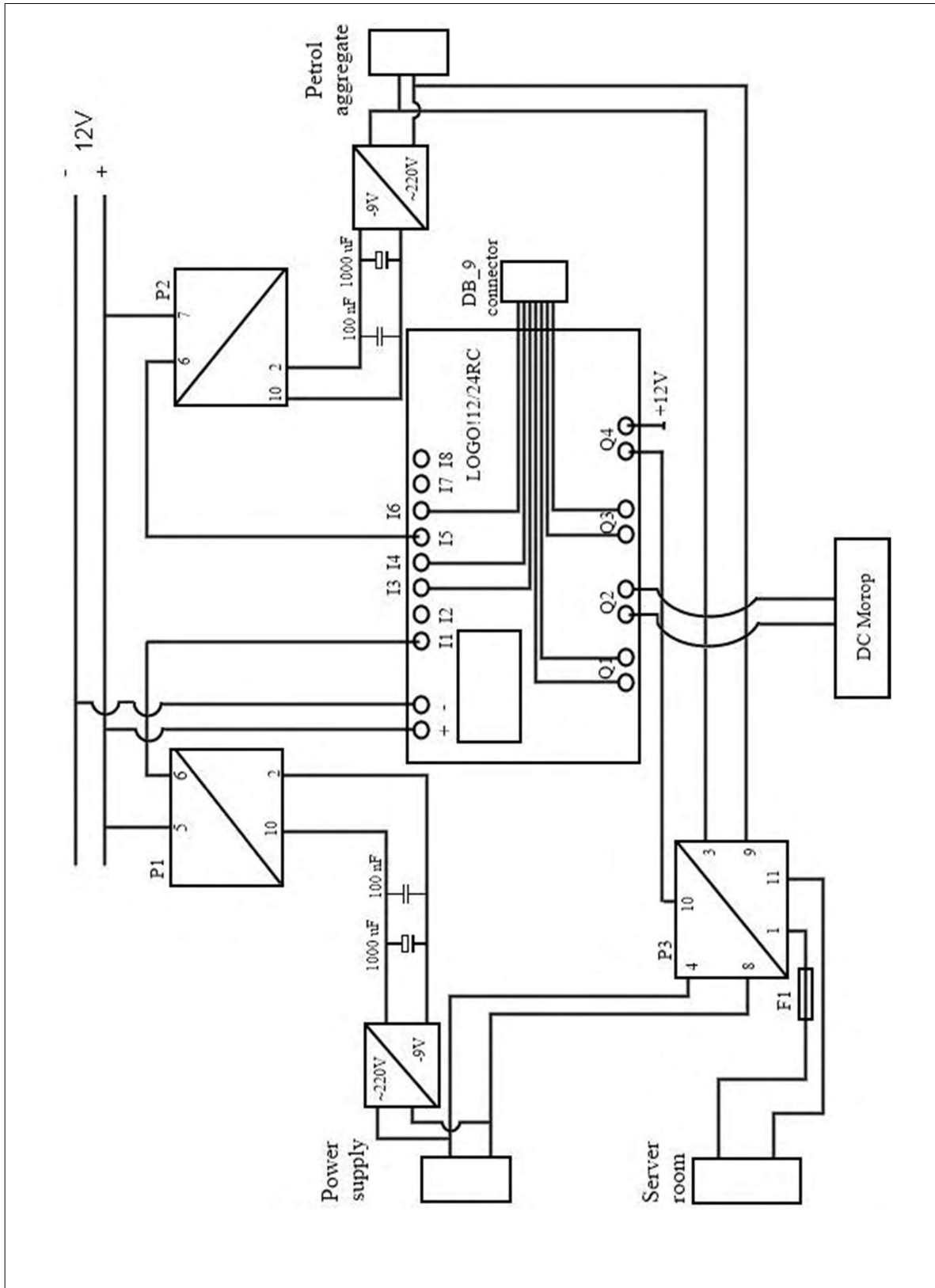

Figure 2. Block diagram of ignition system

- Integrated electrically erasable programmable read-only memory (EEPROM)

The main blocks of the system, which are shown on the Figure 2 are:

- Sensors for monitoring of the presence of the power supply build from a transformer, a filter group and a relay;
- Contactor for switching power to the server room;
- Logical control unit for process management, based on the programmable logic controller (PLC);
- DC motor which controls the position of the choke ignition engine.

The aggregate has a manual choke, which requires the development of connecting rod mechanism for moving the position of the choke shown in Figure 3.

To determine the position of the choke are used three pieces of sensors connected to the inputs of the PLC (I3, I4 and I6).

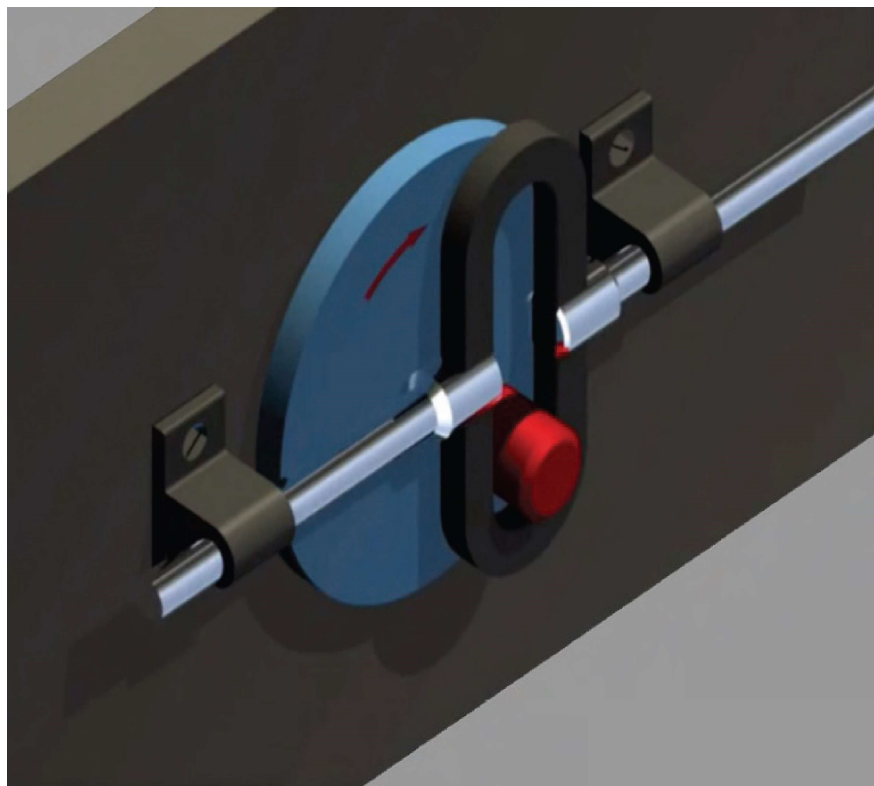

Figure 3. The crutch mechanism

Each of the sensors is attached in a specific position, this guarantees correct positioning of the choke for task execution that has been given. The sensor changes to a state of logical '1' in the case when the choke reaches a specific position.

This is used to cancel the transfer of controlling signal to the motor. The developed program of LOGO! FBD [6] is based on function block diagram (FBD) and implements the following algorithm:

- If there is voltage in the network it is transferred to the input of the on-line UPS, and the output of the UPS powers the server room.

- If there is no power, the UPS powers the server room from battery source.
- The system detects that there is no power supply and initiates a process for starting the aggregate.
- After detecting the presence of the output voltage of the generator, the control system switches the input relay from position '1' to position '2'. The voltage from the generator is transmitted to the server room through the UPS.
- If there is any voltage from the electrical network, the control system waits specified time and sends a turn off signal to the petrol aggregate to switch the input relay from position '2' to position '1'.
- When igniting signal is sent to the electromotor, it starts to move slowly the choke of the petrol generator in two stages. First time to the half of its move in order to ignite and second time to the final position to the established conditions.

3. Development And Realization of the Programming Part

The development of the program carried out by the controller is achieved with the programming product LOGO!Soft Comfort v 6.1. This is a specialized software product, which provides a user-friendly panel and a numerous opportunities. Basics moments from the program development are:

• In case of power down:

When there is no power supply in the electrical network the sensor monitoring its presence and send a signal to the input I1 of the controller. To make sure that the power it's not just a disturbance, a check that the signal from the sensor is available for 20 sec is done. The program implementation of this fragment is as follows: the sensor signal which is transferred to the input I1 of the controller is also transferred to the timer with a relative on delay. The timer constant is set to 20 seconds. This timer guarantees a logical '1' as a value of its output when the value is available at its input for at least 20 seconds (Figure 4). The moment when the input I1 receives a signal a dialog window appears and notifies that there is no power supply in the network and that a process for igniting the aggregate was started.

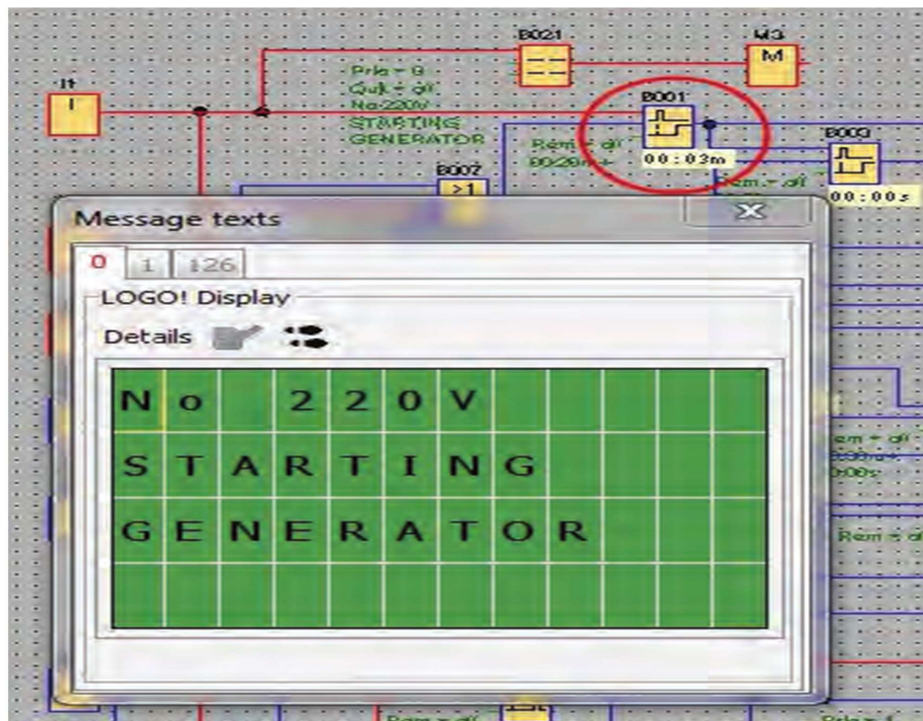

Figure 4. Ignition and move the choke

• **Positioning and moving the choke:**

In order to achieve a smooth changing of the position of the choke the time of the transferred signal, the inertia of the motor should be taken in mind. A pulse width modulation is used. The time of the pulses for working and pausing is very carefully chosen. The smooth movement of the motor is required in order to make a proper assessment on its position.

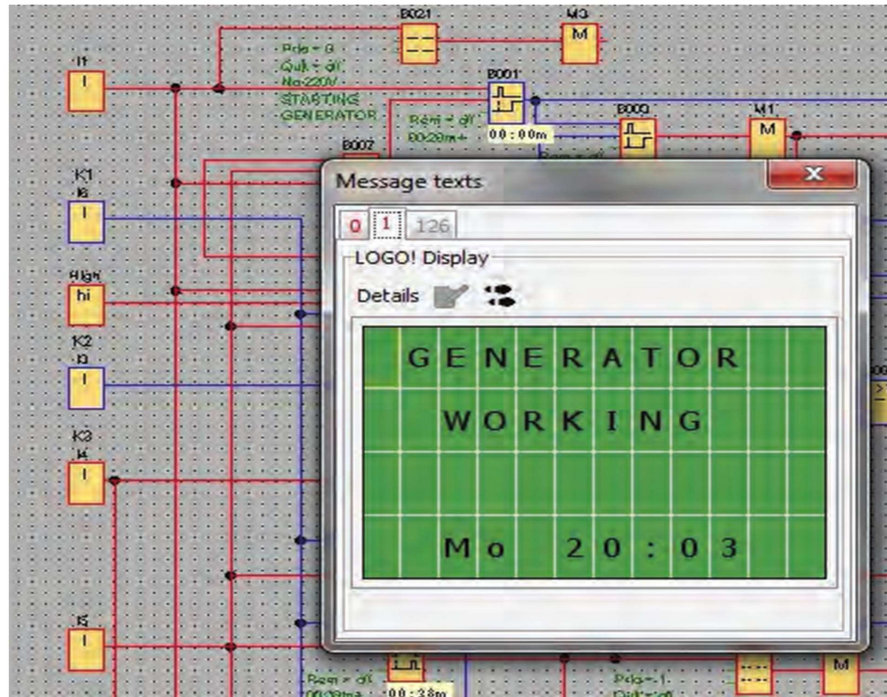

Figure 5. Stable output voltage- 220V, after ignition

To determine the position of the motor, there are 3 sensors connected to the corresponding outputs of the controller (I2, I3 and I4). In the beginning the motor is always in position '1', (I2 = '1') and when it reaches position '2' a signal is sent to the input (I3) from sensor 3 which stops the movement of the motor. Since the DC motor has a large momentum the time for sending control pulse is very little. To that time is also added and the time for commutation of the relay output of the controller and the time for treatment of the signal.

• **Conditions for work of the generator:**

In order to monitor the work of the generator the following conditions must be observed.

There must be no power supply in the network.

The sensor monitoring for a voltage presence must be established in state '1' (I1 = 1). The choke must be in state '3' – at the input (I4) of the controller there should be condition of logical '1'. The sensor monitoring for a voltage presence from the generator must be in state of logical '1' (I5 = '1'), which means that the aggregate has managed to start and at its output a DC is generated with constant frequency.

The counter which monitors the number of unsuccessful ignitions must show 0 – its purpose is to monitor how many times the generator has started. If there is a technical problem or lack of fuel and the generator fails to start more than 5 times the system cancels the process of igniting and on the display of the controller is shown that there were 5 unsuccessful ignites. If the aggregate has managed to start and therefore generates output voltage, the signal from the sensor monitoring for presence of output power resets the counter. In order to guarantee the correct work of the system there are algorithms and check for the correct execution of the program.

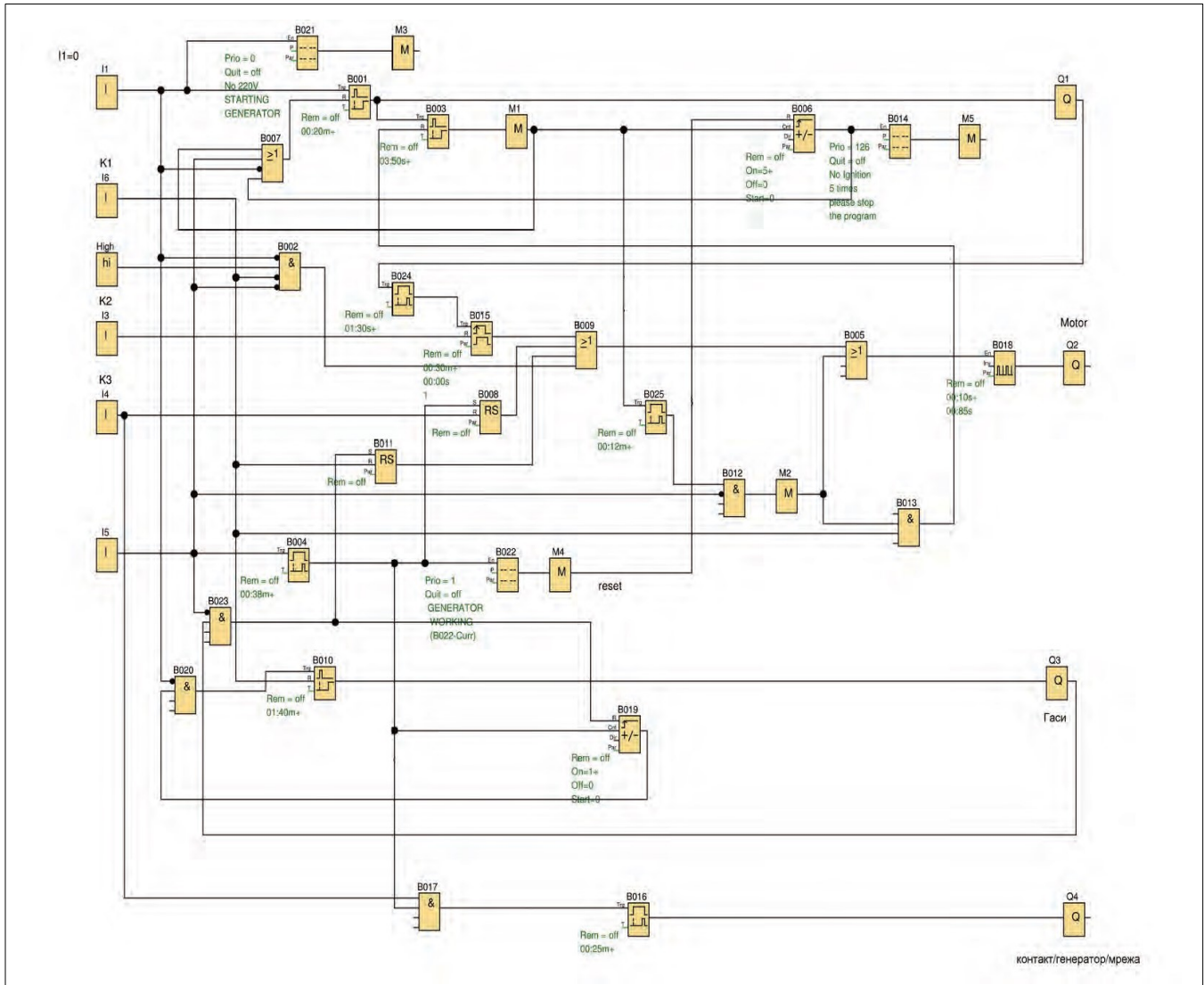

Figure 6. Block diagram of the program

There is a check that ensures that when the system first start the choke will be in position '1' i.e. I2='1'.

There is also a check for the state of all counters used in the scheme. This check resets all counters when the system first starts. There is a protection from a short circuit in the load which guarantees that when a short circuit is present the system will not start the process of igniting. For this implementation a 10A fast - acting fuse is used. Its signal is transferred to the input I7 of the controller. If by some reason there is a short circuit in the load, the control system indicates this on the monitor and permits the ignition of the aggregate. The full program in FBD, on which PLC's work is based, is shown on Figure 6.

Additionally there is a possibility at input I8 to monitor the fuel levels. At critical levels there is a logical '1' at the input and the system displays a message on the monitor: "No fuel".

4. Conclusion

There are autonomous ignition aggregate systems on the market, but they are too expensive. The system we proposed in this article covers the sectors from low and middle business classes where autonomous aggregate is wanted but not affordable. The system is adaptive and successful to use with aggregates with different power levels and having automatic choke. Of course

with bigger loads the power fragment must be recalculated.

References

- [1] McCarthy, K. & Avelar, V. Comparing UPS System Design Configurations, 3rd revision. EDG2, Inc. Schneider Electric.
- [2] Maniktala, S. (2006). “Swiching power suply A to Z” USA Elsavier Inc.
- [3] Erceg, R., Erceg, G. & Tesnjak, S. (1998) Starting of diesel electrical aggregate loaded with an induction motor. *In: Proceedings of the 24th Annual Conference of the IEEE, Industrial Electronics Society*. IECON, Vol. 2, pp. 673–678.
- [4] Jack, H. (2003). Automating Manufacturing jSystems with PLCs.
- [5] Siemens, A.G. (2004). “LOGO!”, Manuale Edition, pp. A5e00228550–A01.
- [6] Siemens, A.G. (1999) LOGO soft Confort! Documentation.