

Khalida Noori<sup>1</sup>, Sami Ahmed Haider<sup>2</sup>

<sup>1</sup>Electrical Engineering Department, Military College of Signals, National University of Sciences and Technology, Pakistan  
khalida@mcs.edu.pk

<sup>2</sup>Electrical Engineering Department, Military College of signals, National University of Sciences and Technology, Pakistan  
sami@mcs.edu.pk

**ABSTRACT:** This paper proposes a simple and efficient method for layered MIMO-OFDM system with channel equalization. Temporal variations in the channel are due to Doppler spread, a sign of relative motion between transmitter and receiver. Results are simulated in both Rayleigh channel and additive white Gaussian noise (AWGN) channel. Decision feedback equalizer (DFE) with recursive least square (RLS) algorithm is used for channel equalization. Different type of Layered structure is applied to MIMO-OFDM system and their performance is evaluated. Different modulation schemes are used with same number of transmit and receive antennas. Simulation results are shown for both vertical and horizontal coded layered structure MIMO-OFDM systems with different modulation schemes and different number of transmit antennas.

### Categories and Subject Descriptors

D.2.6 [Programming Environments]; Graphical Environments: .2.5 [Testing and debugging]; I.3.6 [Methodology and Techniques]; Graphics data structures and data types

### General Terms

Graph Theory, Software Testing, Graph Decomposition

**Keywords:** Vienna development method, Graphsdecomposition algorithm, VDM

Received 11 Nov. 2006; Revised and accepted 17 Feb. 2007

## 1. Introduction

High transmission data rate, spectral efficiency, and reliability are necessary for future wireless communication systems. Deploying multiple antennas at both transmitter and receiver in wireless channel, achieves high data rate and capacity without increasing total transmission power or bandwidth. Orthogonal Frequency Division Multiplexing (OFDM) is a multi-carrier transmission technique proposed in mid 1960's [1]. In frequency-selective channel, delay spread of the channel impulse response introduces inter-symbol interference (ISI) in a single carrier system, which causes severe system performance degradation if not taken care of. OFDM effectively counters the channel delay spread by converting channel into a number of overlapping but mutually orthogonal sub-channels in frequency domain. Multiple Input Multiple Output Orthogonal Frequency Division

Multiplexing (MIMO-OFDM) system is an effective solution to improve communication quality, performance, capacity, and transmission rate. MIMO-OFDM is a promising technology that embraces advantages of both MIMO system and OFDM, i.e., immunity to delay spread as well as huge transmission capacity. Different types of Space time codes were applied to MIMO-OFDM system to increase the capacity [2]. They have a potential drawback that the decoder complexity grows exponentially with the number of bits per symbol thus limiting the achievable data rates [3, 4]. Foschini proposed a coding

technique called layered structure that offers a low complexity solution to realize the attractive capacity of MIMO –OFDM systems [5]. Layered structure has shown its potential as a low-complexity, low-cost solution to future wireless communication systems with huge increase in spectrum efficiency and throughput [6]. Most of work done in this paper is to enhance performance of layered structure MIMO-OFDM systems in terms of BER. This paper is organized as follows; second and third section is about MIMO and MIMO-OFDM system. Section four describes layered structure and the remaining section provides simulation results.

## 2. MIMO System

In MIMO transmission, if antennas are well separated, the signals at different antennas experience independent fading in a dispersal environment. Consider T transmits antennas and R receives antennas as shown in the Figure 1.

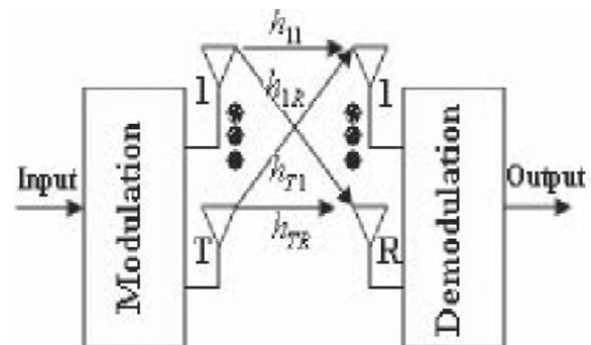

Figure 1. Block diagram of MIMO system

Let  $h_{TR}$  be the channel coefficient between the Tth transmit antenna and Rth receive antenna. Let  $X = [X_1 \ X_2 \ \dots \ X_T]^T$  be the transmitted data and  $Y = [Y_1 \ Y_2 \ \dots \ Y_R]^T$  be the received data, 'T' stands for transpose operation. In matrix form, the relation is given by

$$\begin{bmatrix} Y_1 \\ \vdots \\ Y_R \end{bmatrix} = \begin{bmatrix} h_{11} & \dots & h_{T1} \\ \vdots & \dots & \vdots \\ h_{R1} & \dots & h_{TR} \end{bmatrix} \begin{bmatrix} X_1 \\ \vdots \\ X_T \end{bmatrix} + \begin{bmatrix} \omega_1 \\ \vdots \\ \omega_R \end{bmatrix}$$

## 3. MIMO OFDM System

Equation 1 shows expression for a MIMO-OFDM system with T transmit and R receive antennas, the received signal at the k-th sub-carrier of the n-th block from the j-th receive antenna:

$$y_j[n, k] = \sum_{i=1}^T H_{ji}[n, k] x_i[n, k] + \omega_j[n, k] \quad (1)$$

for  $j = 1, \dots, R$  and  $k = 0, \dots, K - 1$ , where  $x_i[n, k]$  is the symbol transmitted from the  $i$ -th transmit antenna at the  $k$ -th sub-carrier of the  $n$ -th block,  $H_{ji}[n, k]$  is the channel's frequency response at the  $k$ -th sub-carrier of the  $n$ -th block corresponding to the  $i$ -th transmit and the  $j$ -th receive antenna, and,  $\omega_j[n, k]$  is additive (complex) Gaussian noise. Block diagram of MIMO OFDM system is shown in Figure 2.

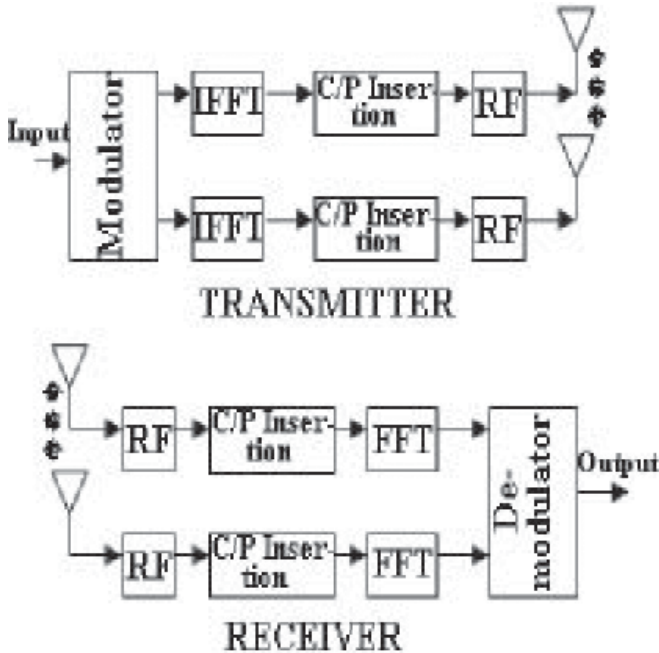

Figure 2. System diagram of MIMO OFDM system

#### 4. Layered MIMO OFDM System

Main tool for increasing the transmission rate with multiple transmit antennas system consist of transmitting more independent streams, or layers of data from all available transmit antennas, simultaneously. In more specific terms, if we have a system with  $N$  transmit antennas, we can transmit, simultaneously,  $N_t$  independent symbols one from each transmit antenna. At the receiver, we can get, at any time instant  $N_r$  observations one from each receive antenna. Therefore at any time instant, we have a system of  $N_r$  observations in  $N_t$  unknowns.

#### 5. Simulation Setup

Before presenting the simulation results, first the parameters of simulated Layered MIMO OFDM system is described. Simulation is also done for vertical and horizontal layered structure MIMO-OFDM system. OFDM system with 32 subcarriers is used. Different modulation scheme are used with same number of transmit and receive antennas. Recursive least algorithm (RLS) is used for channel estimation.

#### 6. Implementation of MIMO OFDM Systems

Figure 3 shows block diagram of a MIMO OFDM system with 2 transmit and 2 receive antennas according to which simulation is done.

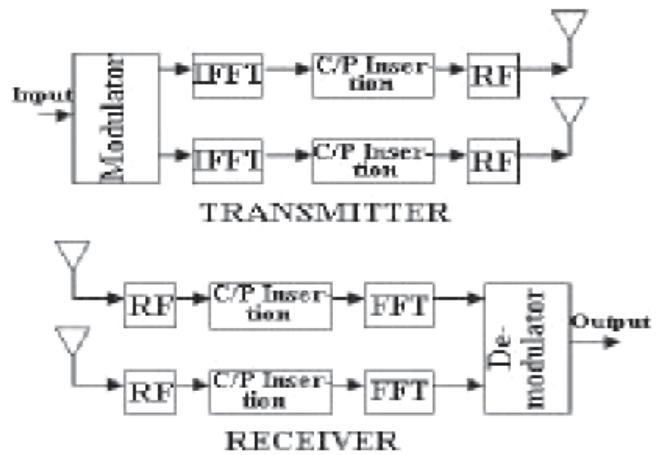

Figure 3. System diagram of MIMO OFDM system

#### 6. 1 Simulation results

Simulation result shows the bit error rate (BER) of MIMO-OFDM system having 32 sub-carriers, with two transmits and two receive antennas over a Rayleigh fading with additive white Gaussian noise (AWGN) channel. It is noticeable that the bit error rate reduces as the signal to noise ratio increases.

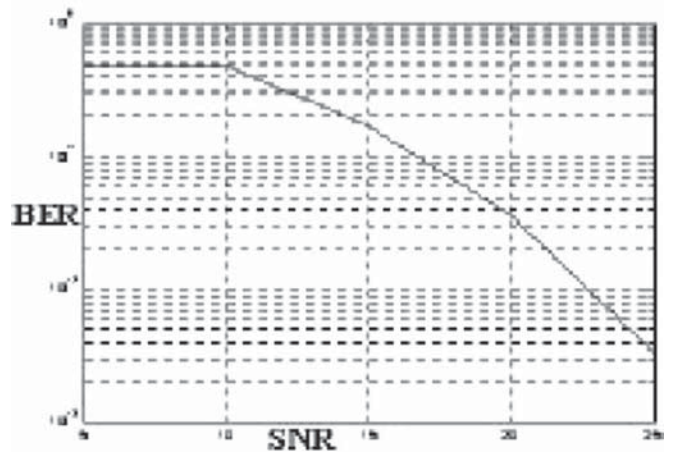

Figure 4. BER plot of MIMO OFDM system

#### 7. Implementation of Layered MIMO OFDM Systems

##### 7.1 -Vertical layered MIMO OFDM system

Figure 5 shows block diagram of vertical layered structure MIMO OFDM system according to which simulation is done.

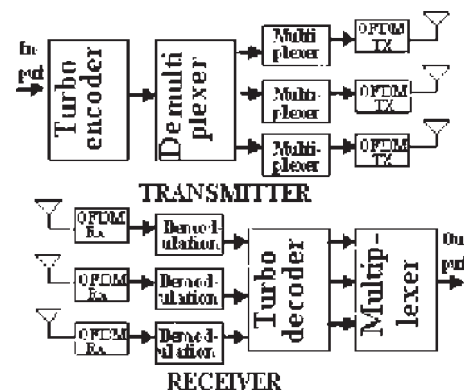

Figure 5. System diagram of Vertical Layered MIMO OFDM System with three transmit and three receive antennas

## 7.2 Simulation results

Simulation result shows the bit error rate (BER) of vertical LST architecture OFDM system having 32 sub-carriers, with three transmits and three receives antennas over a Rayleigh fading with additive white Gaussian noise (AWGN) channel. On the x-axis is signal to noise ratio and on y-axis is bit error rate. It is in plain sight that the bit error rate reduces as the signal to noise ratio increases. At approximately 16dB, BER is  $10^{-6}$ , whereas at 19dB, BER is  $10^{-9}$ .

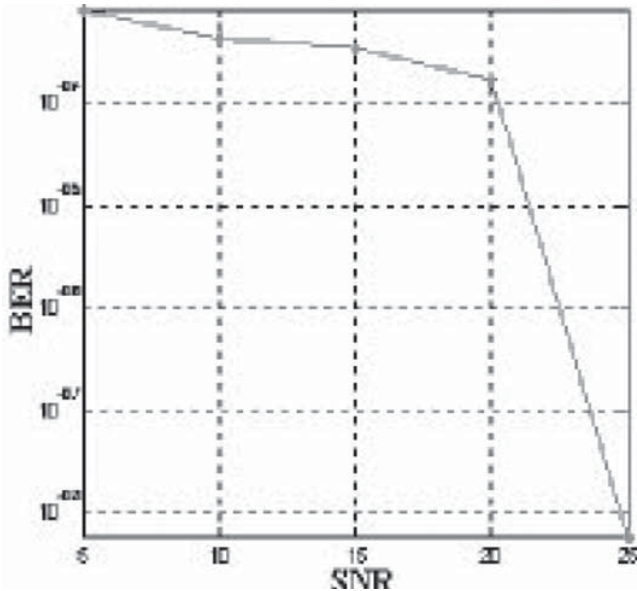

Figure 6. BER plot of vertical layered MIMO OFDM system

## 7.3 Horizontal layered MIMO OFDM system

Figure 9 shows the block diagram of horizontal coded layered structure MIMO OFDM system with two transmit and two receive antennas.

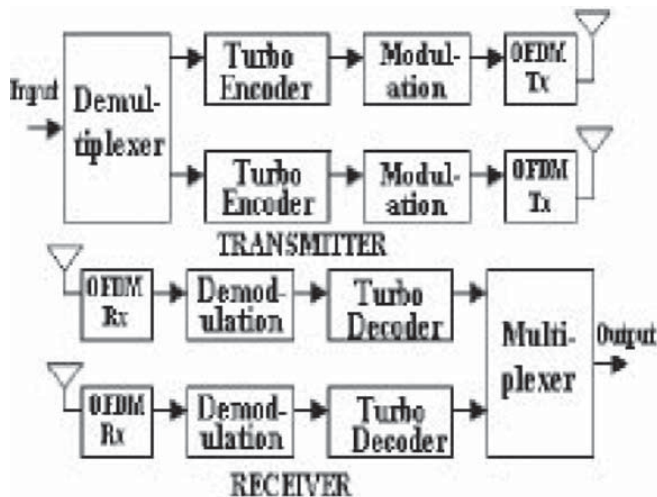

Figure 7. Block diagram of horizontal coded layered structure MIMO OFDM system with two transmit and two receive antennas

## 7.4 Simulation results

Simulation result shows the bit error rate (BER) of horizontal coded LST architecture OFDM system having 32 sub-carriers, with two transmit and two receive antennas over a Rayleigh

fading with additive white Gaussian noise (AWGN) channel. On the x-axis is signal to noise ratio and on y-axis is the bit error rate. It can analyze from the Figure 8 that the bit error rate reduces as the signal to noise ratio increases. 02

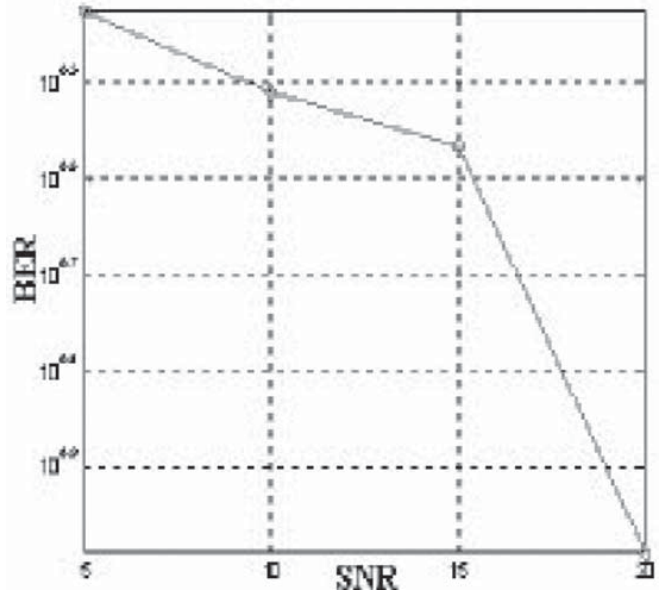

Figure 8. BER of horizontal layered structure MIMO OFDM system

## 8. Conclusion

In this paper, a technique for layered MIMO OFDM is proposed with low complexity that uses the RLS algorithm for channel estimation. Turbo codes are used in layered architecture which gives best complexity/performance trade off. BER of different layered architecture is analyzed. On basis of the simulated results, it was concluded that the layered structure has low bit error rate as compared to previous coding schemes. It is shown through numerical simulations that high performance gain is achieved in layered MIMO OFDM system.

## References

- [1] Wang, Xiaodang (2005). OFDM and its application to 4G, 14th annual conference on wireless and optical communications, USA, p. 69-71.
- [2] Chee, Lim Wei, Kannan, B., Chin, Francois (2002). MIMO Capacity Performance for Both Narrowband and Wideband Systems, 8th international conference on communication system, V. 1, p. 426-430, Nov.
- [3] Paulraj, A.J., Gore, D.A., Nabar, R.U., Bölcskei, H (2004). An overview of MIMO communications - a key to gigabit wireless, Proceedings of the IEEE international conference on communication, V.92, p. 198 - 218, Feb.
- [4] Liu, Zhipeng, Parks, Jeremy S., Morrison, Scott A., Gugel, Karl S. (2004). Implementation and Evaluation of an OFDM-Based MIMO System, IEEE conference on signal, systems and computers, V.1, p. 545-548.
- [5] Foschini, G.J., Gans, M. J (1998). On limits of wireless communications in a fading environment when using multiple antennas, IEEE international conference on wireless personal communications, V.6, Netherlands, p.311-335, Mar. 1998.
- [6] Gamal, H. E., Hammons Jr., A.R (2001). A new approach to layered spacetime coding and signal processing IEEE transactions on information theory, V. 47, p. 2321-2334, Sept. 2001.